



Eikon: 2P 16AX 1-way switch +key grey

20083

Eikon / Devices / Devices - other functions

2P 16AX 1-way switch +key grey

2P 16 AX 250 V~ key-operated 1-way switch, key removable in both positions, grey. Max 200 W for self-ballasted lamps (IEC 60669-1:2017)

Product Status

3 - Active

Minimum order quantity

10 NR

Drawings

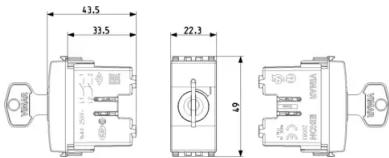

Space view

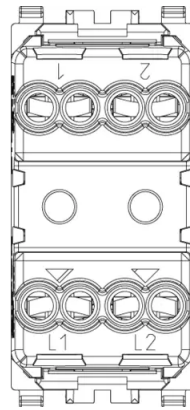

Backside view

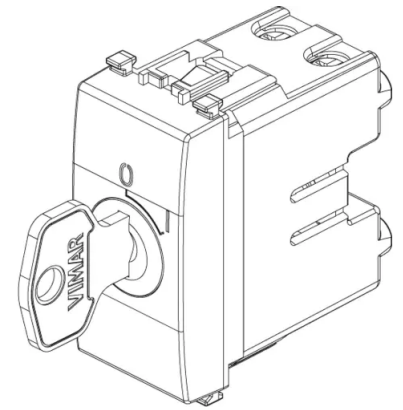

3D View



Technical data

- **Class group:** Domestic switching devices
- **Class:** Installation switch
- **Wiring system:** 2-pole switch
- **Method of operation:** Key
- **Assembly arrangement:** Modular device for domestic switching devices
- **Number of modules (module system):** 1
- **Push button switch:** Yes
- **Number of rockers:** 0
- **Mounting method:** Flush mounted (plaster)
- **Type of fastening:** Engage (snap)
- **With mounting plate:** No
- **Material:** Plastic
- **Material quality:** Thermoplastic
- **Halogen free:** Yes
- **Surface protection:** Untreated
- **Surface finishing:** Matt
- **Colour:** Grey
- **RAL-number (similar):** 7024
- **Label space/information surface:** Yes
- **Illumination:** No
- **Function lighting:** Other
- **Type of lighting:** Other
- **Suitable for degree of protection (IP):** IP40
- **Nominal voltage:** 250 v
- **Rated current:** 16 A
- **Feedback-signal contact:** No
- **Connection type:** Screwed terminal
- **Washing machine switch:** Yes
- **Width of device:** 22,30 mm
- **Height of device:** 49,00 mm
- **Depth of device:** 43,50 mm
- **Built-in depth:** 33,50 mm

Certifications

- 00. CE Marking - EU
- 10. EAC Eurasian Customs Union
- 14. TSE - Turkey ([download](#))
- 20. IRAM - Argentina
- 29. QCERT - Colombia ([download](#))
- 31. TISI - Thailand
- 37. Marking - Morocco
- 96. Electrotechnical expert ([download](#))
- 99. WEEE Directive ([download](#))

Packaging



8 007352 253407
Code 8007352253407
Quantity 1 NR
Dim. 5.1x2.8x5.3 [cm]
Weight 53.13 [g]



8 007352 253414
Code 8007352253414
Quantity 10 NR
Dim. 14.4x11.6x6 [cm]
Weight 575.2 [g]

Legal

Vimar reserves the right to change at any time and without notice the characteristics of the products reported. Installation should be carried out by qualified staff in compliance with the current regulations regarding the installation of electrical equipment in the country where the products are installed. For the terms of use of the information on the product info sheet see [Conditions of Use](#).