



Eikon: Frame 7M +screws

21617

Eikon / Mounting frames / For rectangular boxes

Frame 7M +screws

7-module mounting frame, with screws, for 6/7-module mounting boxes

Product Status

3 - Active

Minimum order quantity

30 NR



You may also be interested in



21617.C - Cover 7M Eikon
mount-frame



07937 - Screw for frame
fixing - 35mm



07939 - Screw for frame
fixing - 50 mm

Drawings

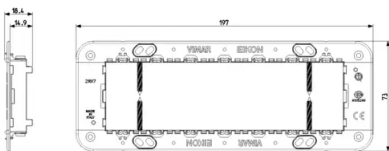

Space view

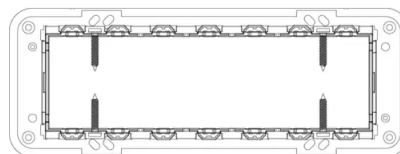

Backside view

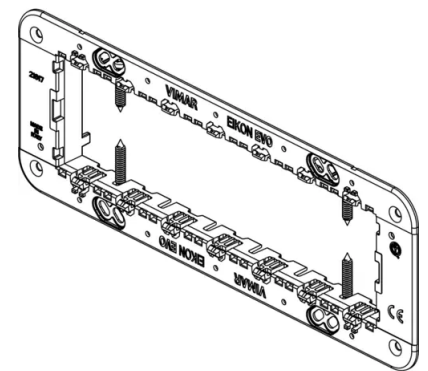

3D View



Gallery



Technical data

- **Class group:** Domestic switching devices
- **Class:** Holder for modular domestic switching devices
- **Model:** Flush mounted (plaster)
- **Mounting method:** Mounting with screw
- **Mounting method of the module inserts:** Front side
- **Mounting direction:** Horizontal and vertical
- **Number of modules horizontal (module system):** 7
- **Number of modules vertical (module system):** 1
- **With built-in installation box:** No
- **With screws:** Yes
- **Suitable for mounting in round junction box 60 mm:** No
- **Flush-mounted installation:** Yes
- **Suitable for floor box:** No
- **Suitable for wall duct:** No
- **Suitable for mounting on DIN-rail 35 mm:** No
- **Material:** Plastic
- **Material quality:** Thermoplastic

Certifications

- 01. IMQ - Italy ([download](#))
- 15. CCC - China ([download](#))
- 29. QCERT - Colombia ([download](#))
- 37. Marking - Morocco
- 96. Electrotechnical expert ([download](#))

Packaging



8 007352 421509
Code 8007352421509
Quantity 1 NR
Dim. 19.7x7.3x1.9 [cm]
Weight 55.86 [g]



8 007352 421516
Code 8007352421516
Quantity 30 NR
Dim. 28.4x24.4x14.9 [cm]
Weight 1,830 [g]



8 007352 626010
Code 8007352626010
Quantity 120 NR
Dim. 60x33x27.5 [cm]
Weight 7,740 [g]

Legal

Vimar reserves the right to change at any time and without notice the characteristics of the products reported. Installation should be carried out by qualified staff in compliance with the current regulations regarding the installation of electrical equipment in the country where the products are installed. For the terms of use of the information on the product info sheet see [Conditions of Use](#).