



Eikon Next: Three 1P 20AX 1-way switches Next

20003.N

Eikon Next / Devices / Basic devices

Three 1P 20AX 1-way switches Next

Three 1P 20 AX 250 V~ 1-way switches, lighttable, Next - 2 modules. Max 250 W for self-ballasted lamps (IEC 60669-1:2017)

Product Status

3 - Active

Minimum order quantity

20 NR



Drawings

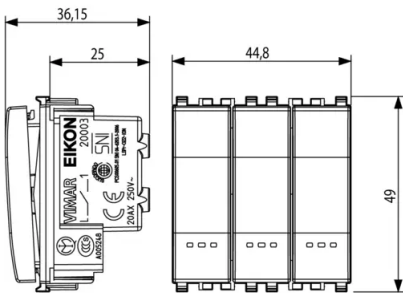

Space view

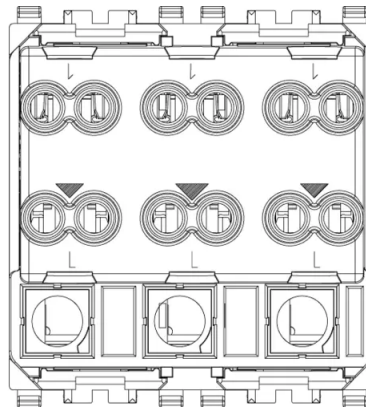

Backside view

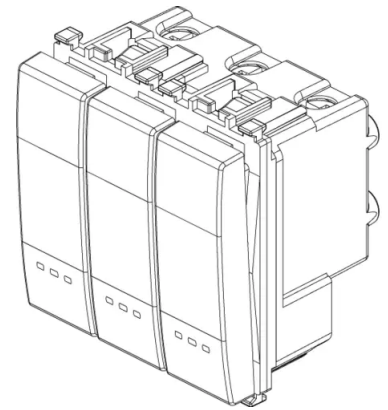

3D View



Technical data

- **Class group:** Domestic switching devices
- **Class:** Installation switch
- **Wiring system:** Off switch 1-pole
- **Method of operation:** Rocker/button
- **Assembly arrangement:** Modular device for domestic switching devices
- **Number of modules (module system):** 2
- **Push button switch:** Yes
- **Number of rockers:** 3
- **Mounting method:** Flush mounted (plaster)
- **Type of fastening:** Engage (snap)
- **With mounting plate:** No
- **Material:** Plastic
- **Material quality:** Thermoplastic
- **Halogen free:** Yes
- **Surface protection:** Lacquered
- **Surface finishing:** Matt
- **Colour:** Silver
- **RAL-number (similar):** 9022
- **Label space/information surface:** Yes
- **Illumination:** Optional
- **Function lighting:** Control and orientation
- **Type of lighting:** LED exchangeable
- **Suitable for degree of protection (IP):** IP40
- **Nominal voltage:** 250 v
- **Rated current:** 20 A
- **Feedback-signal contact:** No
- **Connection type:** Screwed terminal
- **Washing machine switch:** No
- **Width of device:** 44,80 mm
- **Height of device:** 49,00 mm
- **Depth of device:** 36,80 mm
- **Built-in depth:** 25,00 mm

Certifications

- 00. CE Marking - EU
- 01. IMQ - Italy ([download](#))
- 10. EAC Eurasian Customs Union
- 13. SNI - Indonesia
- 15. CCC - China ([download](#))
- 19. NOM - Mexico
- 31. TISI - Thailand
- 37. Marking - Morocco
- 96. Electrotechnical expert ([download](#))
- 99. WEEE Directive ([download](#))

Packaging



8 007352 404021
Code 8007352404021
Quantity 1 NR
Dim. 5.1x4.3x5.3 [cm]
Weight 57.16 [g]



8 007352 404038
Code 8007352404038
Quantity 20 NR
Dim. 26.9x11.6x9 [cm]
Weight 1,223.7 [g]

Legal

Vimar reserves the right to change at any time and without notice the characteristics of the products reported. Installation should be carried out by qualified staff in compliance with the current regulations regarding the installation of electrical equipment in the country where the products are installed. For the terms of use of the information on the product info sheet see [Conditions of Use](#).