



Eikon: 1P 16AX reversing switch mechanism

20013.0

Eikon / Devices / Basic devices

1P 16AX reversing switch mechanism

1P 16 AX 250 V~ reversing switch mechanism, lightable, to complete with 1, 2 or 3-module button. Max 200 W for self-ballasted lamps (IEC 60669-1:2017)

Product Status

3 - Active

Minimum order quantity

10 NR



Drawings

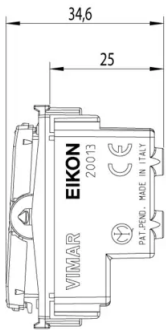

Space view

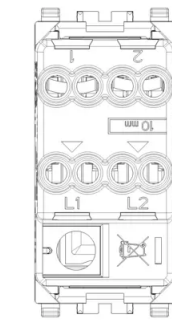
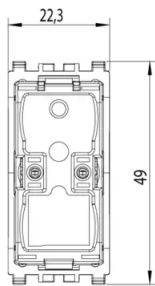

Backside view

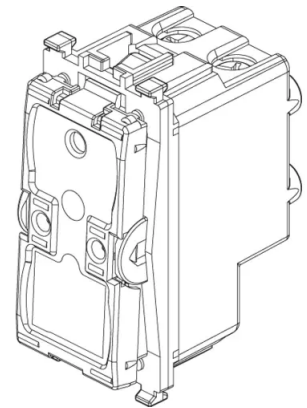

3D View



Technical data

- **Class group:** Domestic switching devices
- **Class:** Installation switch
- **Wiring system:** Intermediate switch
- **Method of operation:** Rocker/button
- **Assembly arrangement:** Modular device for domestic switching devices
- **Number of modules (module system):** 1
- **Push button switch:** Yes
- **Number of rockers:** 1
- **Mounting method:** Flush mounted (plaster)
- **Type of fastening:** Engage (snap)
- **With mounting plate:** No
- **Material:** Plastic
- **Material quality:** Thermoplastic
- **Halogen free:** Yes
- **Surface protection:** Untreated
- **Surface finishing:** Matt
- **Colour:** Anthracite
- **RAL-number (similar):** 7024
- **Label space/information surface:** Yes
- **Illumination:** Optional
- **Function lighting:** Control and orientation
- **Type of lighting:** LED exchangeable
- **Suitable for degree of protection (IP):** IP40
- **Nominal voltage:** 250 v
- **Rated current:** 16 A
- **Feedback-signal contact:** No
- **Connection type:** Screwed terminal
- **Washing machine switch:** No
- **Width of device:** 22,30 mm
- **Height of device:** 49,00 mm
- **Depth of device:** 34,60 mm
- **Built-in depth:** 25,00 mm

Certifications

- 00. CE Marking - EU
- 01. IMQ - Italy ([download](#))
- 10. EAC Eurasian Customs Union
- 14. TSE - Turkey ([download](#))
- 15. CCC - China ([download](#))
- 19. NOM - Mexico
- 20. IRAM - Argentina
- 28. NSW / RCM - Australia ([download](#))
- 29. QCERT - Colombia ([download](#))
- 36. ISI - India
- 37. Marking - Morocco
- 92. RoHS UAE
- 96. Electrotechnical expert ([download](#))
- 99. WEEE Directive ([download](#))

Packaging



8 0 0 7 3 5 2 2 5 0 7 4 1
Code 8007352250741
Quantity 1 NR
Dim. 4.1x2.8x5.3 [cm]
Weight 31 [g]



8 0 0 7 3 5 2 2 5 0 7 5 8
Code 8007352250758
Quantity 10 NR
Dim. 14.4x9x6 [cm]
Weight 345.4 [g]



8 0 0 7 3 5 2 6 4 0 8 3 2
Code 8007352640832
Quantity 160 NR
Dim. 37.5x30x13.5 [cm]
Weight 5,880 [g]

Legal

Vimar reserves the right to change at any time and without notice the characteristics of the products reported. Installation should be carried out by qualified staff in compliance with the current regulations regarding the installation of electrical equipment in the country where the products are installed. For the terms of use of the information on the product info sheet see [Conditions of Use](#).