



Eikon Next: Blank module 2M Next

20042.N

Eikon Next / Accessories / Blank module and cable outlet

Blank module 2M Next

Blank module, Next - 2 modules

Product Status

3 - Active

Minimum order quantity

20 NR



Drawings

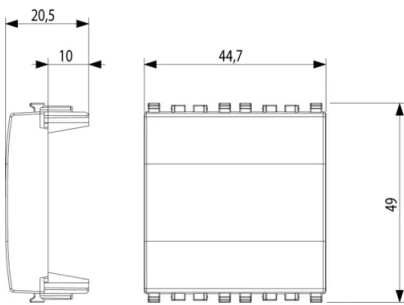

Space view

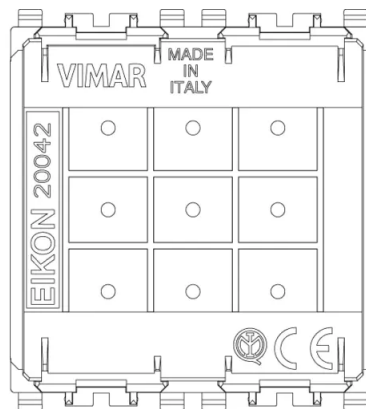

Backside view

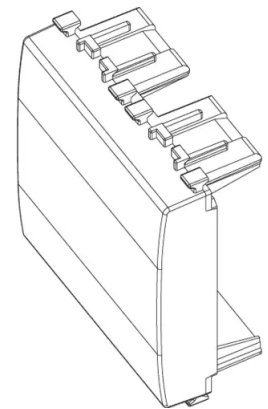

3D View

Technical data

- **Class group:** Domestic switching devices
- **Class:** Push-switch button
- **Method of operation:** Other
- **Number of modules (module system):** 2
- **Nominal voltage:** 0 v
- **Feedback-signal contact:** No
- **Mounting method:** Flush mounted (plaster)
- **Type of fastening:** Mounting with claw
- **Material:** Plastic
- **Material quality:** Thermoplastic
- **Halogen free:** Yes
- **Surface protection:** Lacquered
- **Surface finishing:** Matt
- **Colour:** Silver
- **RAL-number (similar):** 9022
- **Transparent:** No
- **Label space/information surface:** Yes
- **Width of device:** 44,70 mm
- **Height of device:** 49,00 mm
- **Depth of device:** 20,50 mm



Certifications

- 01. IMQ - Italy ([download](#))
- 08. ASTA - UK ([download](#))
- 15. CCC - China ([download](#))
- 29. QCERT - Colombia ([download](#))
- 96. Electrotechnical expert ([download](#))

Packaging



8 0 0 7 3 5 2 3 7 5 2 8 4
Code 8007352375284
Quantity 1 NR
Dim. 4.4x4.9x2 [cm]
Weight 13.05 [g]



8 0 0 7 3 5 2 3 7 5 2 2 2
Code 8007352375222
Quantity 5 NR
Dim. 22x4.9x2 [cm]
Weight 47.9 [g]



8 0 0 7 3 5 2 3 7 5 2 3 9
Code 8007352375239
Quantity 20 NR
Dim. 27x11.6x6 [cm]
Weight 261 [g]



8 0 0 7 3 5 2 6 5 1 3 4 0
Code 8007352651340
Quantity 120 NR
Dim. 37.5x30x13.5 [cm]
Weight 1,920 [g]

Legal

Vimar reserves the right to change at any time and without notice the characteristics of the products reported. Installation should be carried out by qualified staff in compliance with the current regulations regarding the installation of electrical equipment in the country where the products are installed. For the terms of use of the information on the product info sheet see [Conditions of Use](#).