



## Eikon Next: 1P NO 10A cord-operated push button Next

**20052.N**

Eikon Next / Devices / Devices - other functions

### 1P NO 10A cord-operated push button Next

1P NO 10 A 250 V~ cord-operated push button, with 1,5 m cord, Next

### Product Status

3 - Active

### Minimum order quantity

20 NR



## Drawings

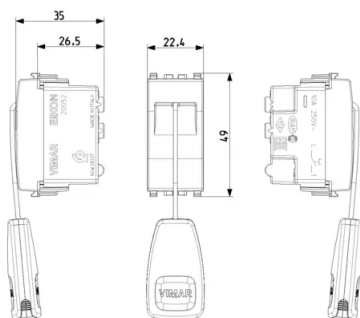

Space view

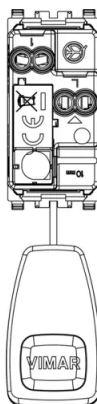

Backside view

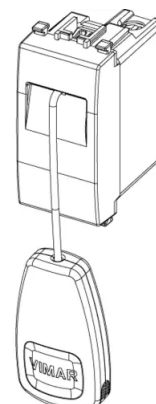

3D View



## Technical data

- **Class group:** Domestic switching devices
- **Class:** Push-switch button
- **Assembly arrangement:** Modular device for domestic switching devices
- **Model:** Other
- **Method of operation:** Push button
- **Number of rockers:** 0
- **Number of modules (module system):** 1
- **Number of poles:** 1
- **Nominal voltage:** 250 v
- **Rated current:** 10,00 A
- **With lighting:** No
- **Feedback-signal contact:** No
- **Mounting method:** Flush mounted (plaster)
- **Type of fastening:** Engage (snap)
- **Material:** Plastic
- **Material quality:** Thermoplastic
- **Halogen free:** Yes
- **Surface protection:** Lacquered
- **Surface finishing:** Matt
- **Colour:** Silver
- **RAL-number (similar):** 9022
- **Transparent:** No
- **Label space/information surface:** Yes
- **Suitable for degree of protection (IP):** IP40
- **Width of device:** 22,30 mm
- **Height of device:** 49,00 mm
- **Depth of device:** 38,50 mm

## Certifications

- 00. CE Marking - EU
- 01. IMQ - Italy ([download](#))
- 10. EAC Eurasian Customs Union
- 14. TSE - Turkey ([download](#))
- 19. NOM - Mexico
- 20. IRAM - Argentina
- 28. NSW / RCM - Australia ([download](#))
- 29. QCERT - Colombia ([download](#))
- 36. ISI - India
- 37. Marking - Morocco
- 96. Electrotechnical expert ([download](#))
- 99. WEEE Directive ([download](#))

## Packaging



8 007352 291416  
**Code** 8007352291416  
**Quantity** 1 NR  
**Dim.** 6x2.8x5.3 [cm]  
**Weight** 32.8 [g]



8 007352 291423  
**Code** 8007352291423  
**Quantity** 20 NR  
**Dim.** 28.1x13.1x6 [cm]  
**Weight** 737 [g]

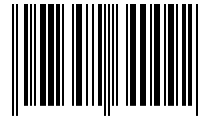

8 007352 640092  
**Code** 8007352640092  
**Quantity** 240 NR  
**Dim.** 38.5x29x30 [cm]  
**Weight** 9,360 [g]

## Legal

Vimar reserves the right to change at any time and without notice the characteristics of the products reported. Installation should be carried out by qualified staff in compliance with the current regulations regarding the installation of electrical equipment in the country where the products are installed. For the terms of use of the information on the product info sheet see [Conditions of Use](#).