



Eikon white: IR relay-switch 230V white

20181.B

Eikon white / Devices / Electronic devices

IR relay-switch 230V white

Automatic lighting switch with IR motion sensor, adjustable dusk/dawn sensor threshold and time-delay cycle, NO 6 A 230 V~ relay output, supply voltage 230 V~ 50-60 Hz, white

Product Status

3 - Active

Minimum order quantity

5 NR

Sheets, Manuals, Documentation

- [Multilanguage instructions sheet \(805 kb\)](#)



Drawings

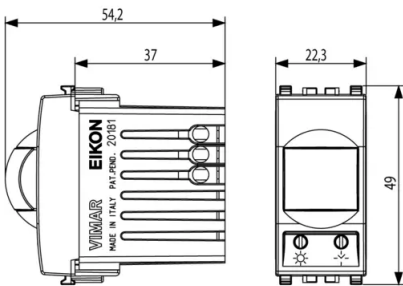

Space view

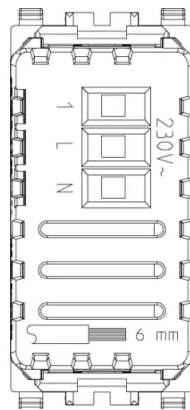

Backside view

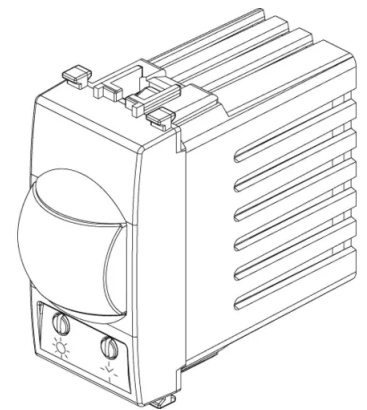

3D View



Technical data

- **Class group:** Domestic switching devices
- **Class:** Electronic insert for domestic switching devices
- **Model:** Other
- **Assembly arrangement:** Modular device for domestic switching devices
- **Number of modules (module system):** 1
- **Radio-controlled:** No
- **Mounting method:** Flush mounted (plaster)
- **Type of fastening:** Engage (snap)
- **Material:** Plastic
- **Material quality:** Thermoplastic
- **Surface protection:** Untreated
- **Surface finishing:** Matt
- **Colour:** White
- **RAL-number (similar):** 9016
- **Transparent:** No

Certifications

- 00. CE Marking - EU
- 01. IMQ - Italy ([download](#))
- 10. EAC Eurasian Customs Union
- 37. Marking - Morocco
- 96. Electrotechnical expert ([download](#))
- 99. WEEE Directive ([download](#))

Packaging



8 0 0 7 3 5 2 3 1 6 2 4 9
Code 8007352316249
Quantity 1 NR
Dim. 5.1x4.3x5.3 [cm]
Weight 53.07 [g]



8 0 0 7 3 5 2 3 1 6 2 5 6
Code 8007352316256
Quantity 5 NR
Dim. 14.4x11.6x6 [cm]
Weight 312.6 [g]



8 0 0 7 3 5 2 6 5 6 9 8 7
Code 8007352656987
Quantity 60 NR
Dim. 36.5x33x13.5 [cm]
Weight 4,170 [g]

Legal

Vimar reserves the right to change at any time and without notice the characteristics of the products reported. Installation should be carried out by qualified staff in compliance with the current regulations regarding the installation of electrical equipment in the country where the products are installed. For the terms of use of the information on the product info sheet see [Conditions of Use](#).