



Eikon white: LED-emergency lamp 3M 120-230V white

20384.B

Eikon white / Devices / Emergency lighting fittings

LED-emergency lamp 3M 120-230V white

Lamp with high-efficiency LED, supply voltage 120-230 V~ 50-60 Hz, automatic emergency device, 3 rechargeable AAA 1,2 V batteries, 1 hour of operating time, white - 3 modules

Product Status

3 - Active

Minimum order quantity

1 NR

Sheets, Manuals, Documentation

- [Multilanguage instructions sheet \(992 kb\)](#)

Drawings

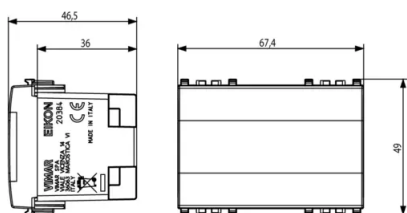

Space view

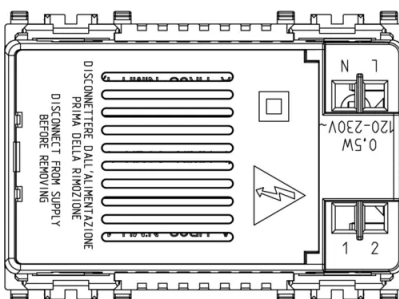

Backside view

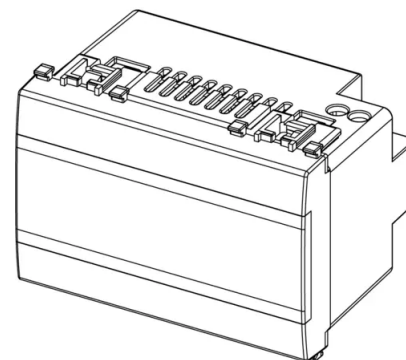

3D View

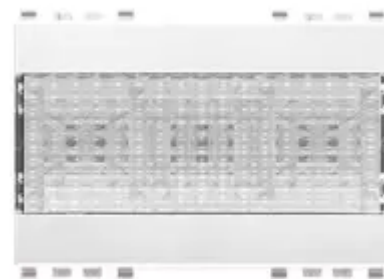



Gallery



Technical data

- **Class group:** Luminaires
- **Class:** Emergency luminaire
- **Mounting method:** Built-in
- **Monitoring equipment:** None
- **Wiring system:** Continuous circuit/emergency circuit
- **With remote switch connection:** No
- **Power supply system:** Peripheral (individual battery)
- **Battery quality:** NiMH
- **Lamp type:** LED not exchangeable
- **With light source:** Yes
- **Material housing:** Plastic
- **Colour housing:** White
- **Material cover:** Without cover
- **Voltage type:** AC
- **Nominal voltage:** 120,00 - 230,00 v
- **Degree of protection (IP):** IP40
- **Protection class:** II
- **Max. system power:** 0,50 W
- **Rated luminous flux according to IEC 62722-2-1:** 22
- **Width:** 67,30 mm
- **Height/depth:** 46,70 mm
- **Built-in height/depth:** 36,50 mm

Certifications

- 00. CE Marking - EU
- 10. EAC Eurasian Customs Union
- 37. Marking - Morocco
- 96. Electrotechnical expert ([download](#))
- 99. WEEE Directive ([download](#))

Packaging



8 007352 314962
Code 8007352314962
Quantity 1 NR
Dim. 11.2x9.6x9.8 [cm]
Weight 185.2 [g]

Legal

Vimar reserves the right to change at any time and without notice the characteristics of the products reported. Installation should be carried out by qualified staff in compliance with the current regulations regarding the installation of electrical equipment in the country where the products are installed. For the terms of use of the information on the product info sheet see [Conditions of Use](#).