



Enclosures and mounting boxes: IP55 cover 3M +screws white

14943.01

Enclosures and mounting boxes / IP40 and IP55 series / IP55 covers - Isoset

IP55 cover 3M +screws white

3-module cover, with screws, for Eikon and Plana series, for 3-module flush mounting boxes, IP55, white

- Suitable for wiring series: Eikon, Arké, Plana
- Isoset enclosures and boxes, Protected and watertight series / IP55 covers Products resistant to dust and water jet ingress from all directions The IP55 protection degree is guaranteed with the cover closed
- The door also provides a locking system for easier opening and closing
- The door consists of an anti-UV membrane
- Captive screws on the power and switching module frame, the frame is not hooked onto the box before screwing



Product Status

3 - Active

Minimum order quantity

2 NR

Drawings

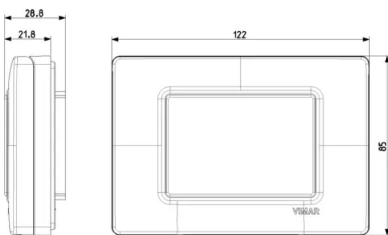

Space view

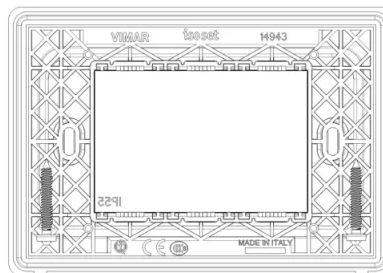

Backside view

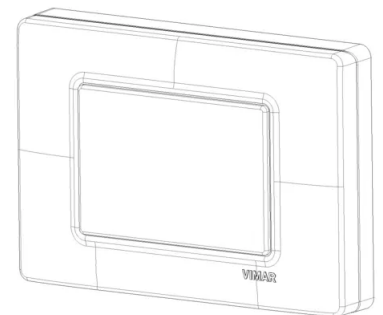

3D View



Gallery



Technical data

- **Class group:** Connection devices
- **Class:** Equipment carrier for insulated walls
- **Material:** Plastic
- **Mounting surfaces:** Other
- **With full insulating materials:** Yes

Certifications

- 00. CE Marking - EU
- 01. IMQ - Italy ([download](#))
- 15. CCC - China ([download](#))
- 37. Marking - Morocco
- 96. Electrotechnical expert ([download](#))

Packaging



8 007352 153981
Code 8007352153981
Quantity 1 NR
Dim. 12.2x8.5x2.2 [cm]
Weight 103.23 [g]



8 007352 153998
Code 8007352153998
Quantity 2 NR
Dim. 24.4x8.5x2.2 [cm]
Weight 206.47 [g]



8 007352 154001
Code 8007352154001
Quantity 20 NR
Dim. 28.4x24.4x11.9 [cm]
Weight 2,222.33 [g]



8 007352 650039
Code 8007352650039
Quantity 120 NR
Dim. 59.5x38.5x26.5 [cm]
Weight 14,844 [g]

Legal

Vimar reserves the right to change at any time and without notice the characteristics of the products reported. Installation should be carried out by qualified staff in compliance with the current regulations regarding the installation of electrical equipment in the country where the products are installed. For the terms of use of the information on the product info sheet see [Conditions of Use](#).