



## Neve Up: Button 2M not lightable white

09022

Neve Up / Devices / Basic devices

### Button 2M not lightable white

2-module interchangeable button, non-lightable, white

### Stato prodotto

3 - Active

### Q.tà minima ordine

20 NR



Dis

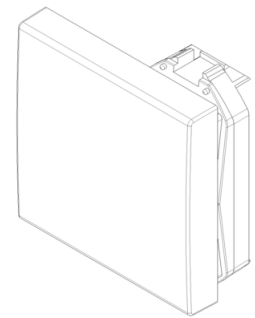
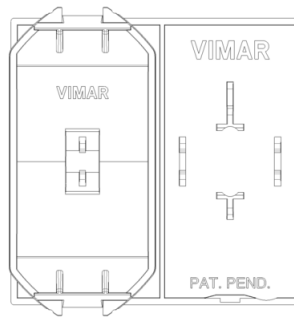
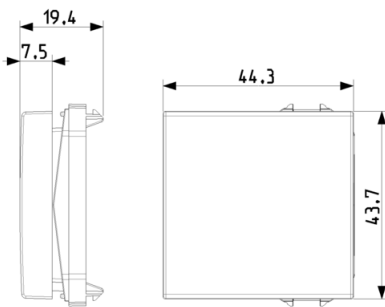

Vista ingombri

Vista posteriore

Vista 3D

## Dati tecnici

- **Class group:** Domestic switching devices
- **Class:** Control element/cover plate for domestic switching devices
- **Model:** Single rocker
- **Utilization:** Switch/push button
- **Suitable for touch sensor connector for bus system:** No
- **Type of fastening:** Clamp mounting
- **Monitoring window/light outlet:** Yes
- **Material:** Plastic

- **Material quality:** Thermoplastic
- **Surface protection:** Untreated
- **Surface finishing:** Glossy
- **Colour:** White
- **RAL-number (similar):** 9016
- **With exchangeable lens/symbol:** No
- **Depth:** 750 mm

## Marchi

- 00. CE Marking - EU
- 29. QCERT - Colombia ([download](#))



## Imballi



8 0 0 7 3 5 2 6 5 9 6 7 4  
**Codice** 8007352659674  
**Qtà** 1 NR  
**Dim.** 4.4x4.3x1.1 [cm]  
**Peso** 14.76 [g]



8 0 0 7 3 5 2 6 5 9 6 8 1  
**Codice** 8007352659681  
**Qtà** 2 NR  
**Dim.** 5.1x2.8x5.3 [cm]  
**Peso** 21.6 [g]



8 0 0 7 3 5 2 6 5 9 6 9 8  
**Codice** 8007352659698  
**Qtà** 20 NR  
**Dim.** 14.4x11.6x6 [cm]  
**Peso** 260.4 [g]



8 0 0 7 3 5 2 6 5 9 7 0 4  
**Codice** 8007352659704  
**Qtà** 240 NR  
**Dim.** 36.5x33x13.5 [cm]  
**Peso** 3,544 [g]

## Legal

Vimar si riserva il diritto di modificare in ogni momento e senza preavviso le caratteristiche dei prodotti riportati. L'installazione deve essere effettuata da personale qualificato con l'osservanza delle disposizioni regolanti l'installazione del materiale elettrico in vigore nel paese dove i prodotti sono installati. Per le condizioni di utilizzo delle informazioni presenti sulla scheda prodotto vedere [Conditions of Use](#).