



## Neve Up: Pushbutton +2 Hotel indicators 230V

**09097**

Neve Up / Devices / Devices - other functions

### Pushbutton +2 Hotel indicators 230V

1P NO 10 A 250 V~ push button with two pilot lights for hotel Do Not Disturb and Please Clean 230V~, white - 2 modules

#### Product Status

3 - Active

#### Minimum order quantity

10 NR



You may also be interested in



09026.PLS - Button 1M  
+diffuser PLS symb.white

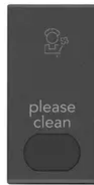

09026.PLS.CM - Button 1M  
+diffuser PLS symb.carbon  
matt



09026.DND - Button 1M  
+diffuser DND symb.white



09026.DND.CM - Button 1M  
+diffuser DND symb. carbon  
m

## Drawings

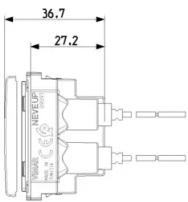

Space view

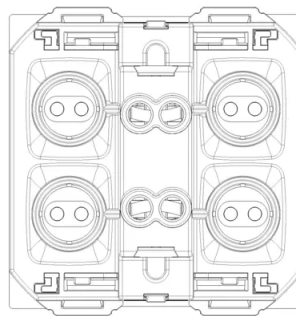
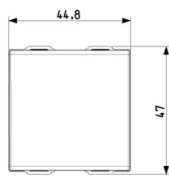

Backside view

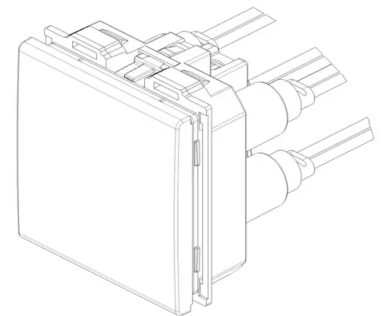

3D View



## Technical data

- **Class group:** Domestic switching devices
- **Class:** Push-switch button
- **Assembly arrangement:** Modular device for domestic switching devices
- **Model:** Single push button
- **Method of operation:** Push button
- **Number of rockers:** 0
- **Number of modules (module system):** 2
- **Nominal voltage:** 250 v
- **Rated current:** 10,00 A
- **Feedback-signal contact:** No
- **Mounting method:** Flush mounted (plaster)
- **Type of fastening:** Engage (snap)
- **Material:** Plastic
- **Material quality:** Thermoplastic
- **Anti-bacterial treatment:** No
- **Surface protection:** Untreated
- **Surface finishing:** Glossy
- **Colour:** White
- **RAL-number (similar):** 9016
- **Transparent:** No
- **Label space/information surface:** Yes
- **Width of device:** 44,80 mm
- **Height of device:** 47,00 mm
- **Depth of device:** 36,70 mm

## Certifications

- 00. CE Marking - EU
- 10. EAC Eurasian Customs Union
- 15. CCC - China ([download](#))
- 19. NOM - Mexico
- 29. QCERT - Colombia ([download](#))
- 37. Marking - Morocco
- 99. WEEE Directive ([download](#))

## Packaging



8 007352 655157  
**Code** 8007352655157  
**Quantity** 1 NR  
**Dim.** 5.1x4.3x5.3 [cm]  
**Weight** 48.8 [g]



8 007352 655164  
**Code** 8007352655164  
**Quantity** 10 NR  
**Dim.** 26.9x11.6x4.9 [cm]  
**Weight** 566 [g]

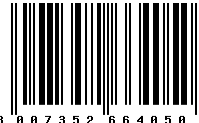

8 007352 664050  
**Code** 8007352664050  
**Quantity** 120 NR  
**Dim.** 38.5x29x30 [cm]  
**Weight** 7,280 [g]

## Legal

Vimar reserves the right to change at any time and without notice the characteristics of the products reported. Installation should be carried out by qualified staff in compliance with the current regulations regarding the installation of electrical equipment in the country where the products are installed. For the terms of use of the information on the product info sheet see [Conditions of Use](#).