



Neve Up: Dimmer 230V 100-500W push-push white

09153

Neve Up / Devices / Electronic devices

Dimmer 230V 100-500W push-push white

Dimmer 230 V~ 50 Hz for 100-500 W incandescent lamps, control via push-push 2-way switch and regulation via rotary potentiometer, visible in darkness, white

Product Status

3 - Active

Minimum order quantity

10 NR



You may also be interested in



09135.1 - Dimmer MASTER
230V universal white



09146 - Dimmer 230V 60-
900W/60-300VA white

Sheets, Manuals, Documentation

- [Multilanguage instructions sheet \(537 kb\)](#)

Drawings

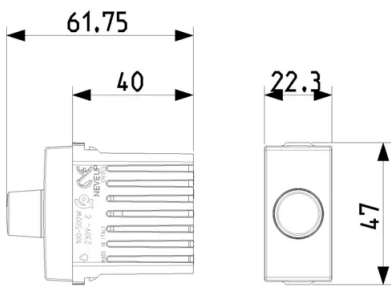

Space view

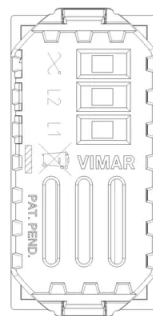

Backside view

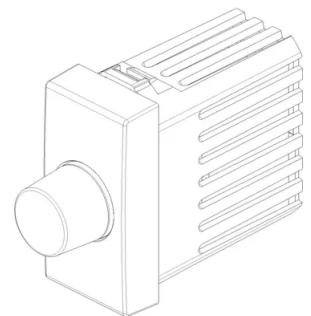

3D View



Technical data

- **Class group:** Domestic switching devices
- **Class:** Push-switch button
- **Method of operation:** Turn button
- **Nominal voltage:** 230 v
- **Feedback-signal contact:** No
- **Mounting method:** Flush mounted (plaster)
- **Material:** Plastic
- **Material quality:** Thermoplastic
- **Surface protection:** Untreated
- **Surface finishing:** Glossy
- **Colour:** White
- **RAL-number (similar):** 9003
- **Transparent:** No
- **Label space/information surface:** Yes
- **Width of device:** 22,30 mm
- **Height of device:** 47,00 mm
- **Depth of device:** 61,75 mm

Certifications

- 00. CE Marking - EU
- 01. IMQ - Italy ([download](#))
- 10. EAC Eurasian Customs Union
- 37. Marking - Morocco
- 96. Electrotechnical expert ([download](#))
- 99. WEEE Directive ([download](#))

Packaging



8 007352 297036
Code 8007352297036
Quantity 1 NR
Dim. 5.3x3.9x7.6 [cm]
Weight 67.6 [g]



8 007352 297043
Code 8007352297043
Quantity 10 NR
Dim. 28.1x13.1x6 [cm]
Weight 757.07 [g]



8 007352 297050
Code 8007352297050
Quantity 120 NR
Dim. 38.5x29x30 [cm]
Weight 8,628 [g]

Legal

Vimar reserves the right to change at any time and without notice the characteristics of the products reported. Installation should be carried out by qualified staff in compliance with the current regulations regarding the installation of electrical equipment in the country where the products are installed. For the terms of use of the information on the product info sheet see [Conditions of Use](#).