



Neve Up: Button 1M customizable CarbonMatt

09021.G.CM

Neve Up / Devices / Basic devices

Button 1M customizable CarbonMatt

Stato prodotto

3 - Active

Q.tà minima ordine

50 NR



Dis

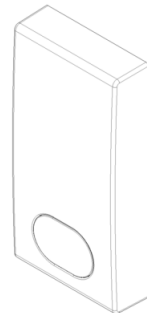
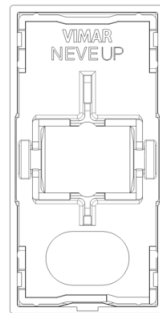
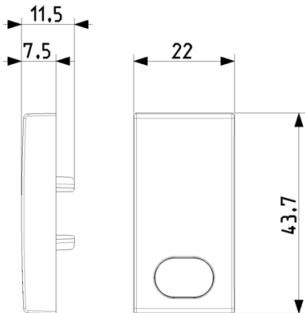

Vista ingombri

Vista posteriore

Vista 3D

Dati tecnici

- **Class group:** Domestic switching devices
- **Class:** Control element/cover plate for domestic switching devices
- **Model:** Single rocker
- **Imprint/indication:** None
- **Scannable symbol/barrier free:** No
- **Utilization:** Switch/push button
- **Suitable for touch sensor connector for bus system:** No
- **Type of fastening:** Clamp mounting
- **Monitoring window/light outlet:** Yes
- **Material:** Plastic
- **Material quality:** Thermoplastic
- **Halogen free:** Yes
- **Surface protection:** Lacquered
- **Surface finishing:** Glossy
- **Colour:** Anthracite
- **RAL-number (similar):** 7024
- **With label area:** No
- **With exchangeable lens/symbol:** No
- **Suitable for degree of protection (IP):** IP40
- **Depth:** 750 mm



Marchi

- 00. CE Marking - EU

Imballi



8 007352 675636
Codice 8007352675636
Qtà 1 NR
Dim. 2.2x4.4x1.1 [cm]
Peso 4 [g]



8 007352 675643
Codice 8007352675643
Qtà 5 NR
Dim. 5.1x2.8x5.3 [cm]
Peso 24.2 [g]



8 007352 675650
Codice 8007352675650
Qtà 50 NR
Dim. 14.4x11.6x6 [cm]
Peso 283.6 [g]



8 007352 675667
Codice 8007352675667
Qtà 600 NR
Dim. 36.5x33x13.5 [cm]
Peso 3,206 [g]

Legal

Vimar si riserva il diritto di modificare in ogni momento e senza preavviso le caratteristiche dei prodotti riportati. L'installazione deve essere effettuata da personale qualificato con l'osservanza delle disposizioni regolanti l'installazione del materiale elettrico in vigore nel paese dove i prodotti sono installati. Per le condizioni di utilizzo delle informazioni presenti sulla scheda prodotto vedere [Conditions of Use](#).