



Neve Up: Button 1M key symbol carbon matt

09021.P.CM

Neve Up / Devices / Basic devices

Button 1M key symbol carbon matt

1-module interchangeable button, lightTable key symbol, carbon matt

Product Status

3 - Active

Minimum order quantity

50 NR



You may also be interested in



09021.P.CM - Button 1M key symbol carbon matt



09008.0.250 - 1P NO 10A push button mechan.+pilot 250V

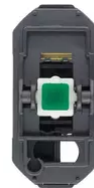

09008.0.12 - 1P NO 10A push button mechan.+pilot 12V



09005.0.250 - 1P 16AX 2-way switch mechan.+pilot 250V

Drawings

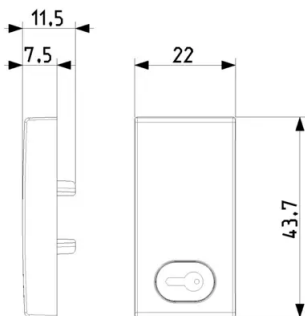

Space view

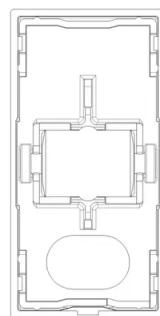

Backside view

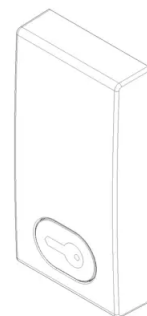

3D View



Technical data

- **Class group:** Domestic switching devices
- **Class:** Control element/cover plate for domestic switching devices
- **Model:** Single rocker
- **Utilization:** Switch/push button
- **Suitable for touch sensor connector for bus system:** No
- **Type of fastening:** Clamp mounting
- **Monitoring window/light outlet:** Yes
- **Material:** Plastic
- **Material quality:** Thermoplastic
- **Surface protection:** Lacquered
- **Surface finishing:** Matt
- **Colour:** Anthracite
- **RAL-number (similar):** 7016
- **With exchangeable lens/symbol:** Yes
- **Depth:** 750 mm

Certifications

- 00. CE Marking - EU
- 29. QCERT - Colombia ([download](#))

Packaging



8 007352 659377
Code 8007352659377
Quantity 1 NR
Dim. 2.2x4.4x1.1 [cm]
Weight 6.45 [g]



8 007352 659384
Code 8007352659384
Quantity 5 NR
Dim. 5.1x2.8x5.3 [cm]
Weight 24.4 [g]

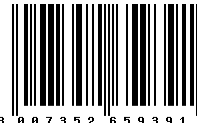

8 007352 659391
Code 8007352659391
Quantity 50 NR
Dim. 14.4x11.6x6 [cm]
Weight 287.4 [g]



8 007352 668676
Code 8007352668676
Quantity 600 NR
Dim. 36.5x33x13.5 [cm]
Weight 2,682 [g]

Legal

Vimar reserves the right to change at any time and without notice the characteristics of the products reported. Installation should be carried out by qualified staff in compliance with the current regulations regarding the installation of electrical equipment in the country where the products are installed. For the terms of use of the information on the product info sheet see [Conditions of Use](#).