

Информационен лист | Номер на артикул: 2006-1302

3-проводна проходна клема; 6 mm²; подходящ за Ex e II приложения; странично и централно маркиране; за DIN шина 35 x 15 и 35 x 7.5; Push-in CAGE CLAMP®; 6,00 mm²; оранжев

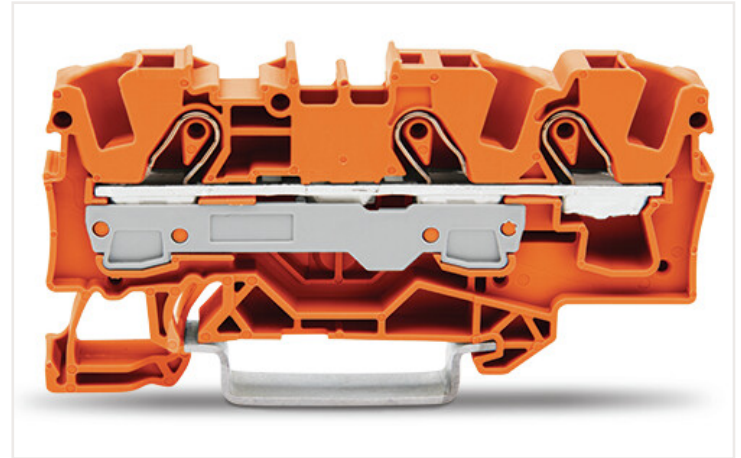

<https://www.wago.com/2006-1302>

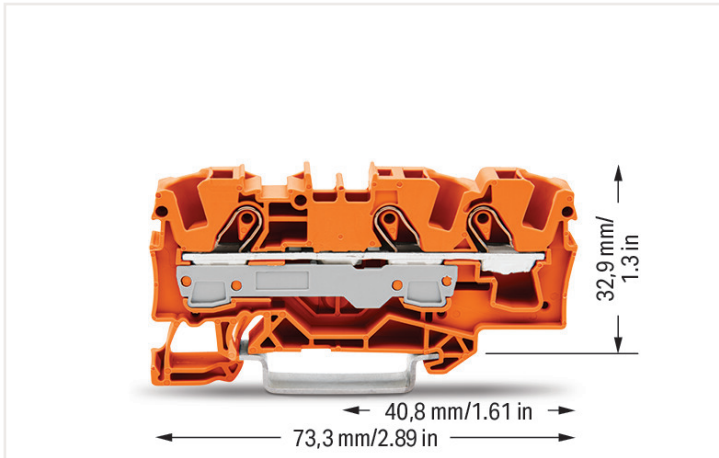

Цвят: ■ оранжев

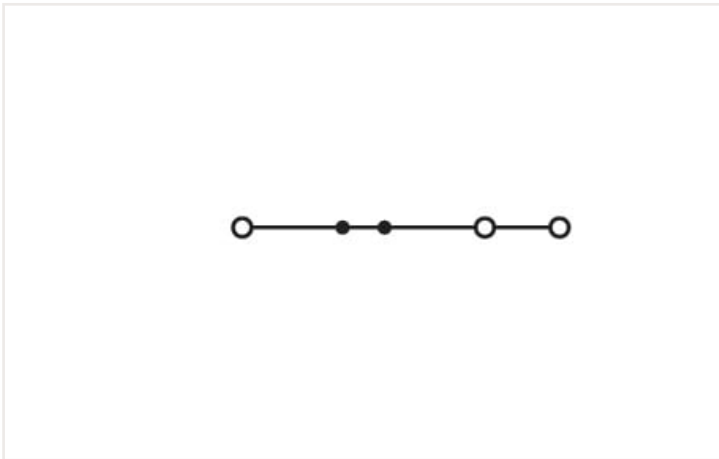

Electrical data

Ratings per IEC/EN

Ratings per	IEC/EN 60947-7-1
Nominal voltage (III/3)	800 V
Rated impulse voltage (III/3)	8 kV
Rated current	41 A
Rated current 2	57 A
Legend (ratings)	(III / 3) ≙ Overvoltage category III / Pollution degree 3

Ratings per UL

Approvals per	UL 1059
Rated voltage UL (Use Group B)	600 V
Rated current UL (Use Group B)	50 A
Rated voltage UL (Use Group C)	600 V
Rated current UL (Use Group C)	50 A

Ratings per CSA

Approvals per	C22.2 No 158
Rated voltage CSA (Use Group B)	600 V
Rated current CSA (Use Group B)	50 A
Rated voltage CSA (Use Group C)	600 V
Rated current CSA (Use Group C)	50 A

Ex information

Reference hazardous areas	See installation notes in section "Knowledge" and Downloads – Documentation – Additional Information: Technical Section; Technical explanations
Ratings per	ATEX: PTB 05 ATEX 1030 U / IECEx: PTB 05.0014U (Ex eb IIC Gb)
Rated voltage EN (Ex e II)	550 V
Rated current (Ex e II)	36 A
Rated current (Ex e II) with jumper	33 A

Connection data

Total number of connection points	3
Total number of potentials	1
Number of levels	1
Number of jumper slots	2

Connection 1

Connection technology	Push-in CAGE CLAMP®
Actuation type	Push-in Operating tool
Connectable conductor materials	Copper
Nominal cross-section	6 mm ²
Solid conductor	0,5 ... 10 mm ² / 20 ... 8 AWG
Solid conductor; push-in termination	2,5 ... 10 mm ² / 14 ... 8 AWG
Fine-stranded conductor	0,5 ... 10 mm ² / 20 ... 8 AWG
Fine-stranded conductor; with insulated ferrule	0,5 ... 6 mm ² / 20 ... 10 AWG
Fine-stranded conductor; with ferrule; push-in termination	2,5 ... 6 mm ² / 16 ... 10 AWG
Note (conductor cross-section)	Depending on the conductor characteristic, a conductor with a smaller cross-section can also be inserted via push-in termination.
Strip length	13 ... 15 mm / 0.51 ... 0.59 inch
Wiring direction	Front-entry wiring

Physical data

Width	7,5 mm / 0.295 inch
Height	73,3 mm / 2.886 inch
Depth from upper-edge of DIN-rail	32,9 mm / 1.295 inch

Mechanical data

Mounting type	DIN-35 rail
Marking level	Center/side marking

Material data

Note (material data)	Information on material data can be found here
Color	оранжев
Insulation material	Polyamide (PA66)
Flammability class per UL94	V0
Fire load	0.02 MJ
Weight	11.8 g

Commercial data

Product Group	22 (TOPJOB S)
eCl@ss 10.0	27-14-11-20
eCl@ss 9.0	27-14-11-20
ETIM 7.0	EC000897
ETIM 6.0	EC000897
PU (SPU)	25 Stück
Packaging type	Box
Country of origin VKOrg Germany	DE
GTIN	4017332999700
Customs tariff number VKOrg Germany	8536901000

Одобрения / Сертификати

Ex-Approvals



Одобрение	Допълнителен текст за одобрение	Име на сертификат
ATEX Physikalisch Technische Bundesanstalt (PTB)	EN 60079	PTB 05 ATEX 1030 U (II 2 G Ex eb IIC Gb bzw. I M 2 Ex eb I Mb)
CCCEX CQST/CNEX	CNCA-C23-01	2020312313000231
EAC Brjansker Zertifizierungsstelle	TP TC 012/2011	RU C-DE.AM02. B.00127/19 (Ex e IIC Gb U)
IECEX Physikalisch Technische Bundesanstalt (PTB)	IEC 60079	IECEX PTB 05.0014 U (Ex eb IIC resp. EX eb I Mb)

Сертификати, специфични за всяка държава



Одобрение	Допълнителен текст за одобрение	Име на сертификат
CCA DEKRA Certification B.V.	IEC 60947	NTR NL 7877
CCA DEKRA Certification B.V.	IEC 60947	71-119205
CSA DEKRA Certification B.V.	C22.2 No. 158	1543858

Сертификати за кораби



Одобрение	Допълнителен текст за одобрение	Име на сертификат
ABS American Bureau of Shipping	EN 60947	20-HG1941090-PDA
BV Bureau Veritas S.A.	EN 60947	38586/A0 BV
DNV GL Det Norske Veritas, Germanischer Lloyd	-	TAE00001V2
LR Lloyds Register	EN 60947	91/20112 (E9)

UL-Approvals



Одобрение	Допълнителен текст за одобрение	Име на сертификат
UL UL International Germany GmbH	UL 1059	E45172

Изтегляния

Documentation

Additional Information

Technical Section	pdf 2142.18 KB	↓
-------------------	-------------------	-------------------

Bid Text

2006-1302	17.04.2019	xml 4.13 KB	↓
2006-1302	17.04.2019	docx 15.06 KB	↓

CAD/CAE-Data

CAD data

2D/3D Models 2006-1302	↓
---------------------------	-------------------

CAE data

EPLAN Data Portal 2006-1302	↓
WSCAD Universe 2006-1302	↓
ZUKEN Portal 2006-1302	↓

1 Съвместими продукти

1.1 Изискват се аксесоари

1.1.1 End plate

1.1.1.1 End plate



Артикул номер: 2006-1392

Крайна и междинна пластина; 1 mm дебелина; оранжев



Артикул номер: 2006-1391

Крайна и междинна пластина; 1 mm дебелина; сив

1.2 Допълнителни аксесоари

1.2.1 Cover

1.2.1.1 Cover



Артикул номер: 2006-191

Затваряща капачка; за поставяне на проводник и задействане на отвор; сив

1.2.2 DIN-rail

1.2.2.1 Mounting accessories



Артикул номер: 210-196

Алуминиева носеща шина; 35 x 8,2 mm; 1,6 mm дебелина; дължина 2 m; без прорези; подобно на EN 60715; сребрист



Артикул номер: 210-198

Медна носеща шина; 35 x 15 mm; 2,3 mm дебелина; дължина 2 m; без прорези; съгласно EN 60715; цвят мед



Артикул номер: 210-114

Стоманена носеща шина; 35 x 15 mm; 1,5 mm дебелина; дължина 2 m; без прорези; подобно на EN 60715; сребрист



Артикул номер: 210-506

Стоманена носеща шина; 35 x 15 mm; 1,5 mm дебелина; дължина 2 m; без прорези; поцинкован; подобно на EN 60715; сребрист



Артикул номер: 210-197

Стоманена носеща шина; 35 x 15 mm; 1,5 mm дебелина; дължина 2 m; с прорези; подобно на EN 60715; сребрист



Артикул номер: 210-508

Стоманена носеща шина; 35 x 15 mm; 1,5 mm дебелина; дължина 2 m; с прорези; поцинкован; подобно на EN 60715; сребрист



Артикул номер: 210-118

Стоманена носеща шина; 35 x 15 mm; 2,3 mm дебелина; дължина 2 m; без прорези; съгласно EN 60715; сребрист



Артикул номер: 210-505

Стоманена носеща шина; 35 x 7,5 mm; 1 mm дебелина; дължина 2 m; без прорези; поцинкован; съгласно EN 60715; сребрист



Артикул номер: 210-113

Стоманена носеща шина; 35 x 7,5 mm; 1 mm дебелина; дължина 2 m; без прорези; съгласно EN 60715; сребрист



Артикул номер: 210-504

Стоманена носеща шина; 35 x 7,5 mm; 1 mm дебелина; дължина 2 m; с прорези; поцинкован; съгласно EN 60715; сребрист



Артикул номер: 210-115

Стоманена носеща шина; 35 x 7,5 mm; 1 mm дебелина; дължина 2 m; с прорези; съгласно EN 60715; "Ширина на отвора 18 mm; сребрист



Артикул номер: 210-112

Стоманена носеща шина; 35 x 7,5 mm; 1 mm дебелина; дължина 2 m; с прорези; съгласно EN 60715; "Ширина на отвора 25 mm; сребрист

1.2.3 End plate

1.2.3.1 End plate



Артикул номер: 2006-1394

Разделителна пластина; 2 mm дебелина; уголемен; оранжев



Артикул номер: 2006-1393

Разделителна пластина; 2 mm дебелина; уголемен; сив



Артикул номер: 209-191

Сепаратор за Ex e/Ex i приложения; 3 mm дебелина; 120 mm ширина; оранжев

1.2.4 Ferrule

1.2.4.1 Ferrule



Артикул номер: 216-262

Накрайник; Втулка за 0.75 mm² / 18 AWG; изолиран; електр. калаено покритие; електролитна мед; газонепроницаем; съгл. DIN 46228, Част 4/09.90; сив



Артикул номер: 216-263

Накрайник; Втулка за 1 mm² / AWG 18; изолиран; електр. калаено покритие; електролитна мед; газонепроницаем; съгл. DIN 46228, Част 4/09.90; червен



Артикул номер: 216-264

Накрайник; Втулка за 1.5 mm² / AWG 16; изолиран; електр. калаено покритие; електролитна мед; газонепроницаем; съгл. DIN 46228, Част 4/09.90; черен



Артикул номер: 216-266

Накрайник; Втулка за 2.5 mm² / AWG 14; изолиран; електр. калаено покритие; електролитна мед; газонепроницаем; съгл. DIN 46228, Част 4/09.90; син



Артикул номер: 216-267

Накрайник; Втулка за 4 mm² / AWG 12; изолиран; електр. калаено покритие; електролитна мед; газонепроницаем; съгл. DIN 46228, Част 4/09.90; сив



Артикул номер: 216-208

Накрайник; Втулка за 6 mm² / AWG 10; изолиран; електр. калаено покритие; електролитна мед; газонепроницаем; съгл. DIN 46228, Част 4/09.90; жълт

1.2.5 Installation

1.2.5.1 Mounting accessories



Артикул номер: 709-169

Държач на капак; Тип 3; сив



Артикул номер: 709-156

Капак; Тип 3; подходящ за носещо покритие, тип 3; дължина 1 m; прозрачен

1.2.6 Jumper

1.2.6.1 Jumper



Артикул номер: 2006-405/011-000

Джъмпер за свързване на звезда; 3-пътен; изолиран; светло сив



Артикул номер: 2006-402

Джъмпер; 2-пътен; изолиран; светло сив



Артикул номер: 2006-403

Джъмпер; 3-пътен; изолиран; светло сив



Артикул номер: 2006-404

Джъмпер; 4-пътен; изолиран; светло сив



Артикул номер: 2006-405

Джъмпер; 5-пътен; изолиран; светло сив



Артикул номер: 2006-433

Джъмпер; от 1 до 3; изолиран; светло сив



Артикул номер: 2006-434

Джъмпер; от 1 до 4; изолиран; светло сив



Артикул номер: 2006-435

Джъмпер; от 1 до 5; изолиран; светло сив



Артикул номер: 2006-499

Редуциращ джъмпер; от 2006/2004 до 2004/2002/2001 серия; изолиран; светло сив



Артикул номер: 2016-499

Редуциращ джъмпер; от 2016/2010 до 2010/2006/2004/2002 серия; изолиран; светло сив

1.2.7.2 Marker

**Артикул номер: 793-5501/000-006**

Маркировъчна карта WMB; като карта; за клема с ширина 5 - 17,5 mm; разтегателни от 5 - 5.2 mm; без печат; тип закрепване чрез закопчаване; син

**Артикул номер: 793-5501/000-005**

Маркировъчна карта WMB; като карта; за клема с ширина 5 - 17,5 mm; разтегателни от 5 - 5.2 mm; без печат; тип закрепване чрез закопчаване; червен

**Артикул номер: 793-501**

Маркировъчна карта WMB; като карта; неразтегателни; без печат; тип закрепване чрез закопчаване; бял

**Артикул номер: 793-501/000-024**

Маркировъчна карта WMB; като карта; неразтегателни; без печат; тип закрепване чрез закопчаване; виолетов

**Артикул номер: 793-501/000-002**

Маркировъчна карта WMB; като карта; неразтегателни; без печат; тип закрепване чрез закопчаване; жълт

**Артикул номер: 793-501/000-023**

Маркировъчна карта WMB; като карта; неразтегателни; без печат; тип закрепване чрез закопчаване; зелен

**Артикул номер: 793-501/000-012**

Маркировъчна карта WMB; като карта; неразтегателни; без печат; тип закрепване чрез закопчаване; оранжев

**Артикул номер: 793-501/000-017**

Маркировъчна карта WMB; като карта; неразтегателни; без печат; тип закрепване чрез закопчаване; светло зелен

**Артикул номер: 793-501/000-007**

Маркировъчна карта WMB; като карта; неразтегателни; без печат; тип закрепване чрез закопчаване; сив

**Артикул номер: 793-501/000-006**

Маркировъчна карта WMB; като карта; неразтегателни; без печат; тип закрепване чрез закопчаване; син

**Артикул номер: 793-501/000-005**

Маркировъчна карта WMB; като карта; неразтегателни; без печат; тип закрепване чрез закопчаване; червен

1.2.7.3 Marker carrier

**Артикул номер: 2009-198**

Адаптер; сив

1.2.7.4 Marking strip

**Артикул номер: 2009-110**

Маркиращи ленти; за Smart Printer; на ролка; неразтегателни; без печат; тип закрепване чрез закопчаване; бял

1.2.8 Protective warning marker

1.2.8.1 Cover

**Артикул номер: 2006-115**

Защитно-предупредителен маркер; за 5 клеми; със символ на високо напрежение, черно; жълт

1.2.9 Test and measurement

1.2.9.1 Testing accessories



Артикул номер: 2006-511

Модулен конектор TOPJOB®S; модулен; за слотове за джъмperi; 1-полюсен; 6,00 mm²; сив



Артикул номер: 2006-549

Празен модул; модулен; напр. за прескачане на обединени клеми; сив



Артикул номер: 2009-182

Тестов отклонител; за макс. 2.5 mm²; свързване без инструменти за отделни тестови проводници 0.08 - 2.5 mm; сив



Артикул номер: 210-136

Тестов щепсел; Ø 2 mm; с кабел 500 mm; червен



Артикул номер: 2009-174

Тестов щепселен адаптер; за тестов щепсел Ø 4 mm; за тестване на клеми TOPJOB®S, монтирани на шина; сив

1.2.10 Tool

1.2.10.1 Operating tool



Артикул номер: 210-721

Работен инструмент; Нож: 5.5 x 0.8 mm; с частично изолирана дръжка; многоцветен

Бележки за инсталиране

Conductor termination

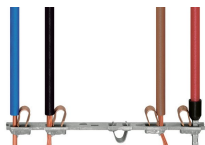

All conductor types at a glance

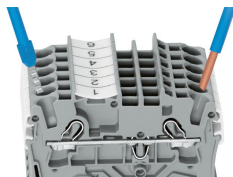

Push-in termination of solid and ferruled conductors

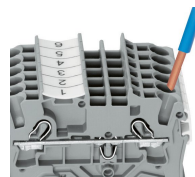

Inserting a conductor via push-in termination:
Solid conductors with cross-sections from either one size above, or up to two sizes below, the rated cross-section can be simply pushed in – no tools needed.

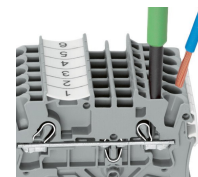

Inserting a conductor via operating tool:
Connecting fine-stranded conductors without ferrules, or small cross-sectional conductors that cannot be pushed in, is performed similarly to the original CAGE CLAMP® – just use an operating tool.
Advantage:
To open the clamp, the operating tool is inserted vertically. The conductor entry is less than 15 degrees for easier wiring.

Commoning

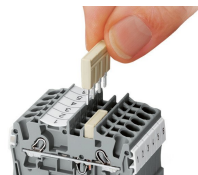

Insert push-in type jumper bar and push down until it hits backstop..

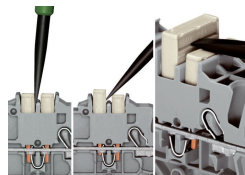

Removing a push-in type jumper bar:
Insert the operating tool between the jumper and partition wall of the dual jumper slots, then lift up the jumper.
Place the operating tool in the center of jumpers for up to five contacts (see above), or alternately on both sides for jumpers with more than five contacts.

Commoning

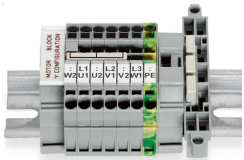

This star point jumper has been specially developed to create a "star point" and is used on motor terminal boards equipped with TOPJOB® S Rail-Mount Terminal Blocks.

Commoning

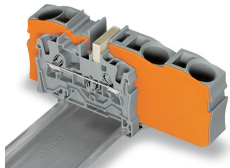

Step-down jumpers common terminal blocks of different sizes, without losing a conductor clamping point. This can be beneficial on long conductor runs where voltage drop can be a problem. A large conductor can be easily connected to smaller conductors at the distribution point.

Commoning may be made in either direction using the special thin end plate to cover the open side. Additional through terminal blocks having a smaller cross-section may be commoned using push-in type jumper bars.

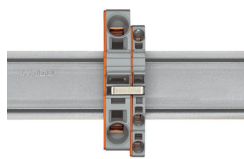

Using step-down jumpers, an end plate must be inserted between the terminal blocks to be commoned.



Step-down jumper (2006-499) commons 6/4 mm² (10/12 AWG) terminal blocks (2006/2004 Series) with 4/2.5/1.5 mm² (AWG 12/14/16) terminal blocks (2004/2002/2001 Series).

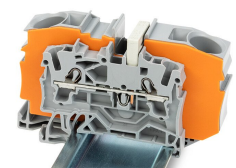

Step-down jumper (2016-499) commons 16/10 mm² (16/8 AWG) terminal blocks (2016/2010 Series) with 10/6/4/2.5 mm² (8/10/12/14 AWG) terminal blocks (2010/2006/2004/2002 Series).

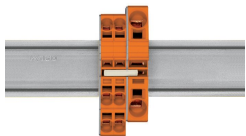

Stepping down via push-in type jumper bar:
Commoning via open terminal side with end plate allows jumpering over two cross-section sizes for 16 mm² (6 AWG) and 10 mm² (8 AWG) and one cross-section size for 6/4/2.5 mm² (10/12/14 AWG). An example: from 16 mm² (6 AWG) to 6 mm² (10 AWG) (see illustration above) or from 10 mm² (8 AWG) to 4 mm² (12 AWG).

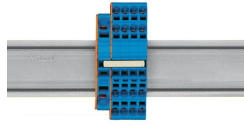

Stepping down via push-in type jumper bar:
Commoning via closed terminal side with end plate allows jumpering over two cross-section sizes, e.g., from 16 mm² (6 AWG) to 6 mm² (10 AWG) or from 6 mm² (10 AWG) to 2.5 mm² (14 AWG) (see illustration above).

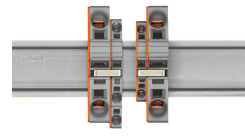

Note:
The total current of the outgoing circuits must not exceed the nominal current of the step-down jumper/push-in type jumper bar.

Testing



The modular TOPJOB® S connectors also connect conductors of the same size as the terminal blocks being used.

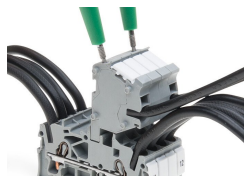

TOPJOB® S Connectors with a 2 mm Ø test socket for testing voltage via 2-pole voltage tester

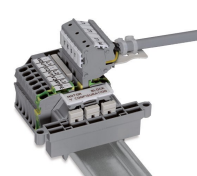

Rail-mount terminal block assembly for electric motor wiring



Test plug adapter (2009-174, CAT I) for 4 mm Ø plugs – compatible with 2000 to 2016 Series

Testing



Testing tap (2009-182) for tool-free connection of test cables up to 2.5 mm² (12 AWG) – compatible with 2000 to 2016 Series

Marking

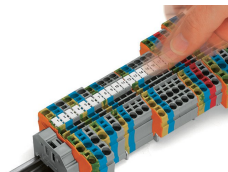

Snapping WMB Inline markers into marker slots.

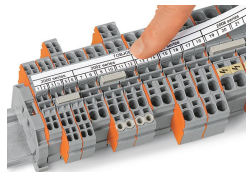

TOPJOB® S 2009-193 Group Marker Carrier (equipped with a marking strip) for all 2001 to 2016 Series TOPJOB® S Rail-Mount Terminal Blocks
Do not use on an end plate!



Ex application

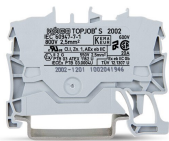

Through terminal blocks with a blue insulated housing are suitable for Ex i applications.

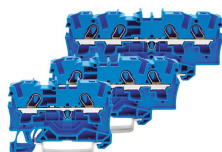

All through and ground conductor terminal blocks are suitable for Ex e II applications.

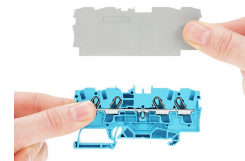

Separator plate for Ex e/Ex i applications
An end plate must be applied to the terminal block located directly behind an Ex e/Ex i separator plate.

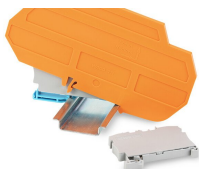

Ex e II/Ex i terminal strip

Note:
The movable feet of terminal blocks and separator plates must face the same direction.

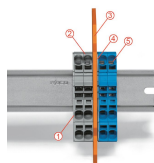

A separator plate is located between the Ex e II and Ex i terminal strip.
End plate
Ex e II terminal blocks
Separator plate for Ex e/Ex i applications
End plate
Ex i terminal blocks
According to EN 50020, a minimum distance of 50 mm must be kept between live parts of Ex e and Ex i circuits. The use of Ex e/Ex i separators is a space-saving solution when Ex e and Ex i terminal blocks are mounted on a common DIN-rail.