



Arké: Vertical badge switch 2M grey

19463

Arké / Systems / Access control system

Vertical badge switch 2M grey

Upright electronic badge switch, 4 A 250 V~ NO (NON SELV) change-over relay output, power supply 120-230 V~ 50-60 Hz, slot lighting for location in the dark, trimmer for regulating switch-off time after removing the card, grey - 2 modules. Supplied without ISO card (badge)

Product Status

3 - Active

Minimum order quantity

1 NR

Sheets, Manuals, Documentation

- [Multilanguage instructions sheet \(1182 kb\)](#)

Video

- [Arké lives in your time](#)

Drawings

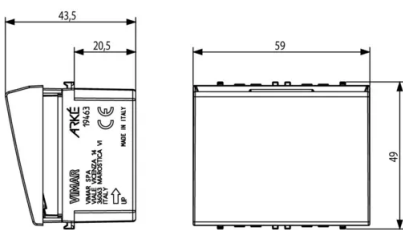

Space view

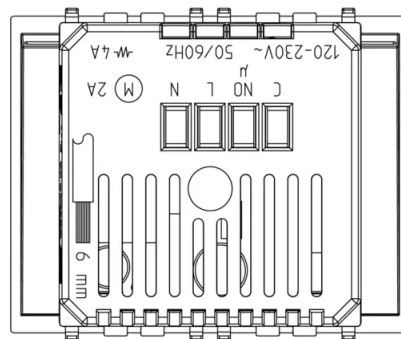

Backside view

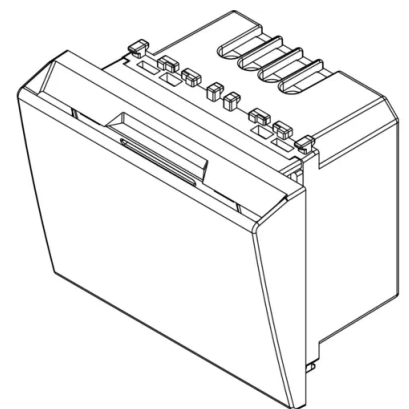

3D View





Technical data

- **Class group:** Alarm installations, emergency call and signalling
- **Class:** Access control system
- **Standalone:** Yes
- **Networkable:** No
- **PC-binding:** No
- **Type of interface:** None
- **Reading strategy:** Data medium
- **Signalling:** None
- **Mounting method:** Flush mounted (plaster)
- **Operating voltage at AC 50 Hz:** 250,00 - 250,01 v
- **Operating voltage at AC 60 Hz:** 250,00 - 250,01 v
- **Operating voltage at DC:** 220,00 - 230,00 v
- **Operating temperature:** -5 - 35 °C
- **Degree of protection (IP):** IP20
- **Colour:** Grey
- **Material:** Plastic
- **Width:** 44,80 mm
- **Height:** 49,00 mm
- **Depth:** 43,50 mm

Certifications

- 00. CE Marking - EU
- 10. EAC Eurasian Customs Union
- 19. NOM - Mexico
- 37. Marking - Morocco
- 99. WEEE Directive ([download](#))

Packaging



8 007352 561380
Code 8007352561380
Quantity 1 NR
Dim. 5.2x5.7x7.6 [cm]
Weight 68.5 [g]



8 007352 563766
Code 8007352563766
Quantity 5 NR
Dim. 21.4x11.6x6 [cm]
Weight 399.3 [g]



8 007352 726093
Code 8007352726093
Quantity 50 NR
Dim. 30.5x25.5x22.5 [cm]
Weight 3,993 [g]

Legal

Vimar reserves the right to change at any time and without notice the characteristics of the products reported. Installation should be carried out by qualified staff in compliance with the current regulations regarding the installation of electrical equipment in the country where the products are installed. For the terms of use of the information on the product info sheet see [Conditions of Use](#).