



Arké: Classic plate 7M technopolymer black

19657.71

Arké / Cover plates / Technopolymer Classic cover plates

Classic plate 7M technopolymer black

7-module Classic cover plate, technopolymer, black

Product Status

3 - Active

Minimum order quantity

5 NR

You may also be interested in



[19617 - Frame 7M +screws](#)

Video

- [Arké lives in your time](#)

Drawings



Space view

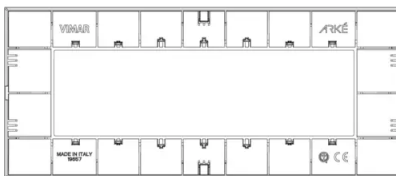

Backside view

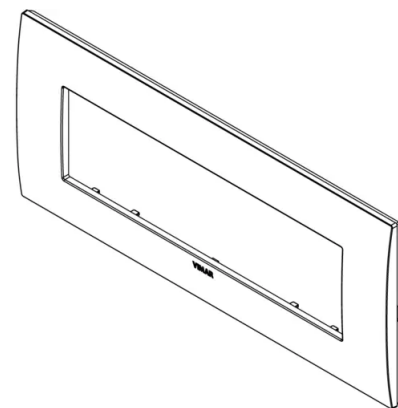

3D View





Gallery



Technical data

- **Class group:** Domestic switching devices
- **Class:** Cover frame for domestic switching devices
- **Number of units:** 7
- **Mounting direction:** Horizontal and vertical
- **Number of units horizontal:** 7
- **Number of units vertical:** 1
- **Number of modules horizontal (module system):** 7
- **Number of modules vertical (module system):** 1
- **Number of switch inserts:** 0
- **With mounting grid:** Yes
- **Suitable for floor box:** Yes
- **Suitable for wall duct:** Yes
- **Suitable for built-in installation:** Yes
- **Label space/information surface:** Yes
- **Material:** Plastic
- **Material quality:** Thermoplastic
- **Halogen free:** Yes
- **Surface protection:** Untreated
- **Surface finishing:** Matt
- **Colour:** Anthracite
- **RAL-number (similar):** 9005
- **Transparent:** No
- **With hinged lid:** No
- **Degree of protection (IP):** IP00
- **Type of fastening:** Clamp mounting
- **Width:** 210,00 mm
- **Height:** 90,00 mm
- **Depth:** 8,60 mm
- **Built-in width:** 210,00 mm
- **Built-in height:** 90,00 mm
- **Diameter bore hole (opening):** 0 mm

Certifications

- 00. CE Marking - EU
- 01. IMQ - Italy ([download](#))
- 29. QCERT - Colombia ([download](#))
- 37. Marking - Morocco
- 43. UKCA mark - Great Britain

Packaging

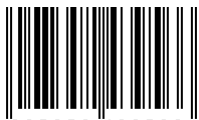

8 007352 439566
Code 8007352439566
Quantity 1 NR
Dim. 21x9x0.9 [cm]
Weight 28.7 [g]

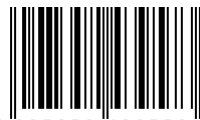

8 007352 439573
Code 8007352439573
Quantity 5 NR
Dim. 24.2x10.3x5.7 [cm]
Weight 197 [g]



Legal

Vimar reserves the right to change at any time and without notice the characteristics of the products reported. Installation should be carried out by qualified staff in compliance with the current regulations regarding the installation of electrical equipment in the country where the products are installed. For the terms of use of the information on the product info sheet see [Conditions of Use](#).