

Data sheet | Item number: 750-459

4-канален аналогов вход; 0 ... 10 VDC; Несимметричен

<https://www.wago.com/750-459>



Color: светло сив

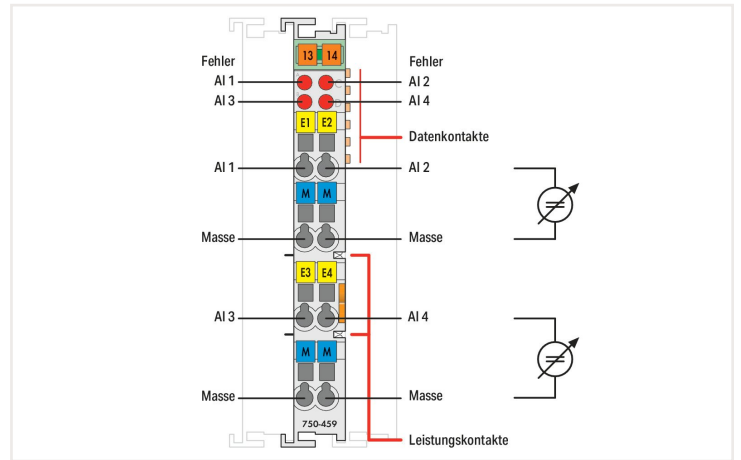
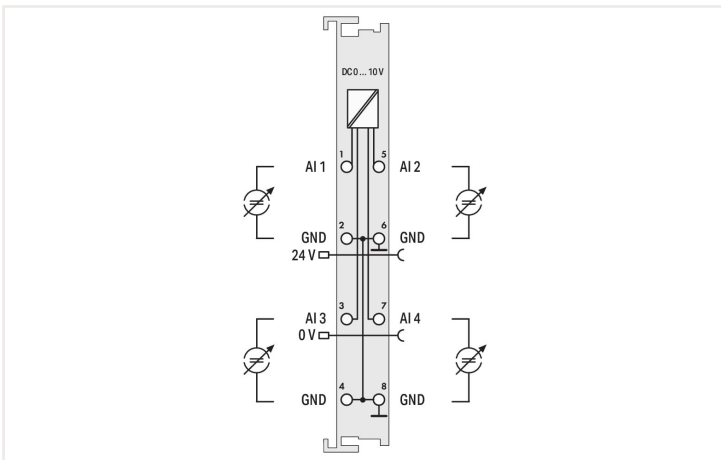
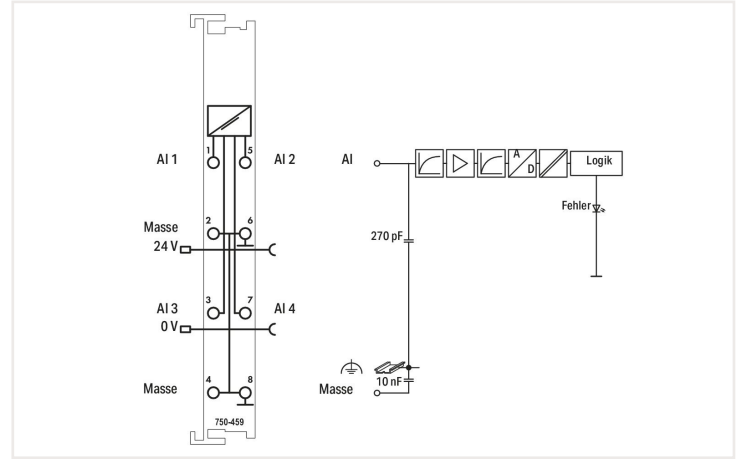

This analog input module processes standard 0–10 V signals.
 The input signal is electrically isolated and is transmitted with a resolution of 12 bits.
 The internal system supply powers the module.
 The input channels of the module have a common ground potential.

Technical data	
Number of analog inputs	4
Total number of channels (module)	4
Signal type	Voltage
Signal type (voltage)	0 ... 10 VDC
Sensor connection	4 x (2-wire)
Input voltage (max.)	±40 V
Signal characteristics	Single-ended
Resolution [bit]	12 bits
Data width	4 x 16-bit data; 4 x 8-bit control/status (optional)
Internal resistance	100 kΩ
Conversion time (typ.)	10 ms
Measurement error (reference temperature)	25 °C
Measurement error, deviation (max.) from the upper-range value	0.1 %
Temperature error (max.) of the upper-range value	0.01 %/K
Supply voltage (system)	5 VDC; via data contacts
Current consumption (5 V system supply)	65 mA
Supply voltage (field)	24 VDC (-25 ... +30 %); via power jumper contacts (power supply via blade contact; transmission via spring contact)
Isolation	500 V system/field
Number of incoming power jumper contacts	2

Technical data

Number of outgoing power jumper contacts	2
--	---

Connection data

Connection technology: inputs/outputs	8 x CAGE CLAMP®
Connection type 1	Inputs/outputs
Solid conductor	0,08 ... 2,5 mm ² / 28 ... 14 AWG
Fine-stranded conductor	0,08 ... 2,5 mm ² / 28 ... 14 AWG
Strip length	8 ... 9 mm / 0.31 ... 0.35 inches

Physical data

Width	12 mm / 0.472 inches
Height	100 mm / 3.937 inches
Depth	69,8 mm / 2.748 inches
Depth from upper-edge of DIN-rail	62,6 mm / 2.465 inches

Mechanical Data

Mounting type	DIN-35 rail
---------------	-------------

Material Data

Color	светло сив
Housing material	Polycarbonate; polyamide 6.6
Fire load	1.543 MJ
Weight	50.8 g
Conformity marking	CE

Environmental requirements

Ambient temperature (operation)	0 ... +55 °C
Surrounding air temperature (storage)	-25 ... +85 °C
Protection type	IP20
Pollution degree (5)	2 per IEC 61131-2
Operating altitude	0 ... 2000 m / 0 ... 6562 ft
Mounting position	horizontal (standing/lying); vertical
Relative humidity (without condensation)	95 %
Vibration resistance	4g per IEC 60068-2-6
Shock resistance	15g per IEC 60068-2-27
EMC immunity to interference	per EN 61000-6-2, marine applications
EMC emission of interference	per EN 61000-6-4, marine applications
Exposure to pollutants	per IEC 60068-2-42 and IEC 60068-2-43
Permissible H ₂ S contaminant concentration at a relative humidity 75 %	10 ppm
Permissible SO ₂ contaminant concentration at a relative humidity 75 %	25 ppm

Commercial data

Product Group	15 (Remote I/O)
eCl@ss 10.0	27-24-26-01
eCl@ss 9.0	27-24-26-01
ETIM 8.0	EC001596
ETIM 7.0	EC001596
PU (SPU)	1 бр.
Packaging type	Box
Country of origin	DE
GTIN	4045454471507
Customs tariff number	85389099990

Approvals and certificates

Общи одобрения



Approval	Standard	Certificate name
EAC Brjansker Zertifizierungsstelle	TP TC 020/2011	EAC RU C-DE.AM02. B.00087/19
KC National Radio Research Agency	Article 58-2, Clause 3	MSIP-REM-W43-AIM750
UL Underwriters Laboratories Inc. (ORDINARY LOCATIONS)	UL 508	E175199 Sec.1

Одобрения за морски приложения



Approval	Standard	Certificate name
ABS American Bureau of Shipping	-	22-2219060
BSH Bundesamt fuer Seeschifffahrt und Hydrographie	-	1104
BV Bureau Veritas S.A.	-	13453/E0 BV
DNV DNV Germany GmbH	DNV-CG-0339, Aug.2021	TAA0000194
KR Korean Register of Shipping	-	KR HMB05880-AC001
LR Lloyds Register EMEA	-	LR22180952TA
PRS Polski Rejestr Statków	-	TE/2236/880590/19
RINA RINA Germany GmbH	-	ELE343521XG001

Одобрения за опасни зони



Approval	Standard	Certificate name
ATEX TUEV Nord Cert GmbH	EN 60079-0	
CCC CNEX	CNCA-C23-01	2020312310000213 (Ex ec IIC T4 Gc)
EAC Brjansker Zertifizierungsstelle	TP TC 012/2011	EAC RU C-DE.AM02. B.00163/19 (2Ex nA IIC T4 Gc X)
IECEX TUEV Nord Cert GmbH	IEC 60079-0	IECEX_TUN_14.0035_X (Ex ec IIC T4 Gc)
INMETRO TUV Rheinland do Brasil Ltda.	IEC 60079-0	BR-Ex_TUV 12.1297 X

Одобрения за опасни зони

UL Underwriters Laboratories Inc. (HAZARDOUS LOCATIONS)	UL 121201	E198726 Sec.1
--	-----------	---------------

Downloads

Documentation

Manual				System Description		
Product Manual 4-channel, 0-10VDC, single-ended	V 1.1.0	pdf	1953.87 KB	750/753 Series I/O-System – General Product Information	pdf	953.35 KB
System Manual WAGO I/O System 750 / 753	V 3.1.0 11.05.2022	pdf	8495.90 KB	Overview on WAGO-I/O-SYSTEM 750 approvals	pdf	770.48 KB
System Manual Series 750/753				Use in Hazardous Environments	V 1.0.0	pdf 1007.06 KB

Bid Text

750-459	19.02.2019	xml	4.16 KB	
750-459	19.10.2017	doc	27.00 KB	
ausschreiben.de 750-459				

CAD/CAE-Data

CAD data	CAE data
2D/3D Models 750-459	EPLAN Data Portal 750-459
	WSCAD Universe 750-459
	ZUKEN Portal 750-459

Device Files

Device Driver			
WAGO USB Service Kabel Treiber / Serie 750 und 857	6.5.3.0 10.09.2014	zip	4721.96 KB

1 Compatible products

1.1 Optional accessories

1.1.1 DIN-rail

1.1.1.1 Mounting accessories



Item no.: 210-196

Алуминиева носеща шина; 35 x 8,2 mm; 1,6 mm дебелина; дължина 2 m; без прорези; подобно на EN 60715; сребрист



Item no.: 210-198

Медна носеща шина; 35 x 15 mm; 2,3 mm дебелина; дължина 2 m; без прорези; съгласно EN 60715; цвят мед



Item no.: 210-114

Стоманена носеща шина; 35 x 15 mm; 1,5 mm дебелина; дължина 2 m; без прорези; подобно на EN 60715; сребрист



Item no.: 210-506

Стоманена носеща шина; 35 x 15 mm; 1,5 mm дебелина; дължина 2 m; без прорези; поцинкован; подобно на EN 60715; сребрист



Item no.: 210-197

Стоманена носеща шина; 35 x 15 mm; 1,5 mm дебелина; дължина 2 m; с прорези; подобно на EN 60715; сребрист



Item no.: 210-508

Стоманена носеща шина; 35 x 15 mm; 1,5 mm дебелина; дължина 2 m; с прорези; поцинкован; подобно на EN 60715; сребрист



Item no.: 210-118

Стоманена носеща шина; 35 x 15 mm; 2,3 mm дебелина; дължина 2 m; без прорези; съгласно EN 60715; сребрист



Item no.: 210-505

Стоманена носеща шина; 35 x 7,5 mm; 1 mm дебелина; дължина 2 m; без прорези; поцинкован; съгласно EN 60715; сребрист



Item no.: 210-113

Стоманена носеща шина; 35 x 7,5 mm; 1 mm дебелина; дължина 2 m; без прорези; съгласно EN 60715; сребрист



Item no.: 210-504

Стоманена носеща шина; 35 x 7,5 mm; 1 mm дебелина; дължина 2 m; с прорези; поцинкован; съгласно EN 60715; сребрист



Item no.: 210-115

Стоманена носеща шина; 35 x 7,5 mm; 1 mm дебелина; дължина 2 m; с прорези; съгласно EN 60715; "Ширина на отвора 18 mm; сребрист



Item no.: 210-112

Стоманена носеща шина; 35 x 7,5 mm; 1 mm дебелина; дължина 2 m; с прорези; съгласно EN 60715; "Ширина на отвора 25 mm; сребрист

1.1.2 Marking

1.1.2.1 Group marker carrier



1.1.2.2 Marker



Item no.: 2009-145

Mini-WSB Inline; за Smart Printer; 1700 броя на ролка; разтегателни от 5 - 5.2 mm; без печат; тип закрепване чрез закопчаване; бял



Item no.: 2009-145/000-024

Mini-WSB Inline; за Smart Printer; 1700 броя на ролка; разтегателни от 5 - 5.2 mm; без печат; тип закрепване чрез закопчаване; виолетов



Item no.: 2009-145/000-002

Mini-WSB Inline; за Smart Printer; 1700 броя на ролка; разтегателни от 5 - 5.2 mm; без печат; тип закрепване чрез закопчаване; жълт



Item no.: 2009-145/000-023

Mini-WSB Inline; за Smart Printer; 1700 броя на ролка; разтегателни от 5 - 5.2 mm; без печат; тип закрепване чрез закопчаване; зелен



Item no.: 2009-145/000-012

Mini-WSB Inline; за Smart Printer; 1700 броя на ролка; разтегателни от 5 - 5.2 mm; без печат; тип закрепване чрез закопчаване; оранжев



Item no.: 2009-145/000-007

Mini-WSB Inline; за Smart Printer; 1700 броя на ролка; разтегателни от 5 - 5.2 mm; без печат; тип закрепване чрез закопчаване; сив



Item no.: 2009-145/000-006

Mini-WSB Inline; за Smart Printer; 1700 броя на ролка; разтегателни от 5 - 5.2 mm; без печат; тип закрепване чрез закопчаване; син



Item no.: 2009-145/000-005

Mini-WSB Inline; за Smart Printer; 1700 броя на ролка; разтегателни от 5 - 5.2 mm; без печат; тип закрепване чрез закопчаване; червен



Item no.: 248-501

Маркировъчна карта Mini-WSB; като карта; неразтегателни; без печат; тип закрепване чрез закопчаване; бял



Item no.: 248-501/000-024

Маркировъчна карта Mini-WSB; като карта; неразтегателни; без печат; тип закрепване чрез закопчаване; виолетов



Item no.: 248-501/000-002

Маркировъчна карта Mini-WSB; като карта; неразтегателни; без печат; тип закрепване чрез закопчаване; жълт



Item no.: 248-501/000-023

Маркировъчна карта Mini-WSB; като карта; неразтегателни; без печат; тип закрепване чрез закопчаване; зелен



Item no.: 248-501/000-012

Маркировъчна карта Mini-WSB; като карта; неразтегателни; без печат; тип закрепване чрез закопчаване; оранжев



Item no.: 248-501/000-017

Маркировъчна карта Mini-WSB; като карта; неразтегателни; без печат; тип закрепване чрез закопчаване; светло зелен



Item no.: 248-501/000-007

Маркировъчна карта Mini-WSB; като карта; неразтегателни; без печат; тип закрепване чрез закопчаване; сив



Item no.: 248-501/000-006

Маркировъчна карта Mini-WSB; като карта; неразтегателни; без печат; тип закрепване чрез закопчаване; син



Item no.: 248-501/000-005

Маркировъчна карта Mini-WSB; като карта; неразтегателни; без печат; тип закрепване чрез закопчаване; червен



Item no.: 750-100

Маркировъчна карта; като лист DIN A4; без печат

1.1.2.3 Marker carrier



Item no.: 750-103

Държач за група маркировъчни табелки

1.1.3 Shield termination

1.1.3.1 Shield clamping saddles



Item no.: 790-108

Екранирана затягаща скоба; 11 mm ширина; диаметър на съвместим проводник; 3 ... 8 mm



Item no.: 790-208

Екранирана затягаща скоба; 12,4 mm ширина; 3 ... 8 mm



Item no.: 790-116

Екранирана затягаща скоба; 19 mm ширина; диаметър на съвместим проводник; 7 ... 16 mm



Item no.: 790-216

Екранирана затягаща скоба; 21,8 mm ширина; 6 ... 16 mm



Item no.: 790-124

Екранирана затягаща скоба; 27 mm ширина; диаметър на съвместим проводник; 6 ... 24 mm



Item no.: 790-220

Екранирана затягаща скоба; 30 mm ширина; 6 ... 20 mm



Item no.: 790-140

Екранирана затягаща скоба; диаметър на съвместим проводник

1.1.4 System enclosure

1.1.4.1 System enclosure



Item no.: 850-825

IP65 корпус; Алюминий (RAL 7032); ШxВxД (160x100x160 mm); 9 x M12, 4 x M20



Item no.: 850-826

IP65 корпус; Алюминий (RAL 7032); ШxВxД (240x100x160 mm); 4 x M20, 4 x M16, винтова връзка 14 x M12



Item no.: 850-827

IP65 корпус; Алюминий (RAL 7032); ШxВxД (320x100x160 mm); 4 x M20, 8 x M16, винтова връзка 17 x M12



Item no.: 850-828

IP65 корпус; Алюминий (RAL 7032); ШxВxД (480x100x160 mm); 4 x M20, 10 x M16, винтова връзка 35 x M12



Item no.: 850-826/002-000

IP65 корпус; Алюминий (RAL 7035); ШxВxД (240x100x160 mm); 4 x M20, 4 x M16, винтова връзка 14 x M12



Item no.: 850-827/002-000

IP65 корпус; Алюминий (RAL 7035); ШxВxД (320x100x160 mm); 4 x M20, 8 x M16, винтова връзка 17 x M12



Item no.: 850-828/002-000

IP65 корпус; Алюминий (RAL 7035); ШxВxД (480x100x160 mm); 4 x M20, 10 x M16, винтова връзка 35 x M12



Item no.: 850-814/002-000

IP65 корпус; Листова стомана (RAL 7035); ШxВxД (200x120x200 mm); без фланцова пластина



Item no.: 850-815/002-000

IP65 корпус; Листова стомана (RAL 7035); ШxВxД (300x120x200 mm); без фланцова пластина



Item no.: 850-816/002-000

IP65 корпус; Листова стомана (RAL 7035); ШxВxД (400x120x200 mm); без фланцова пластина



Item no.: 850-817/002-000

IP65 корпус; Листова стомана (RAL 7035); ШxВxД (600x120x200 mm); без фланцова пластина



Item no.: 850-834

IP65 корпус; Полиестер (RAL 7032); ШxВxД (164x100x164 mm); 9 x M12, 4 x M20



Item no.: 850-835

IP65 корпус; Полиестер (RAL 7032); ШxВxД (244x100x164 mm); 4 x M20, 4 x M16, винтова връзка 14 x M12



Item no.: 850-836

IP65 корпус; Полиестер (RAL 7032); ШxВxД (324x100x164 mm); 4 x M20, 8 x M16, винтова връзка 17 x M12