



ARKÉ: RJ45 slating adaptor grey

19343.K

System infrastructure / Netsafe structured wiring / ARKÉ / Devices

RJ45 slating adaptor grey

Slating adapter for RJ45 Keystone connector, grey

Product Status

3 - Active

Minimum order quantity

20 NR



Drawings

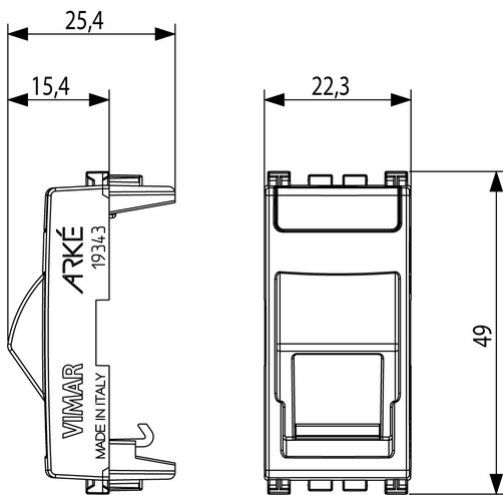

Space view

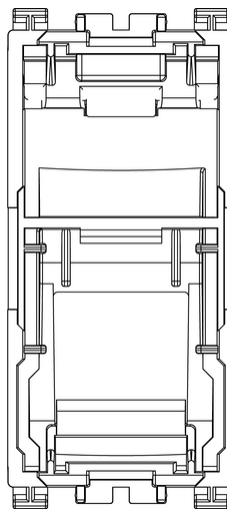

Backside view

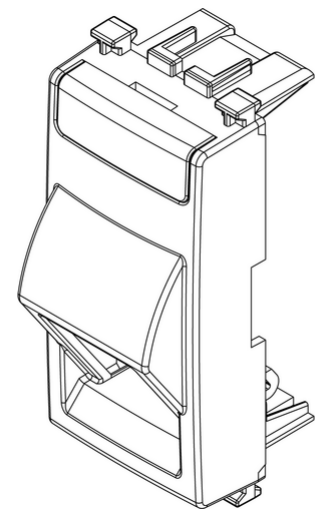

3D View

Certifications

- 00. CE Marking - EU

Technical data

Class group: Domestic switching devices

Class: Transition adaptor for domestic switching devices

Colour: Grey

RAL-number (similar): 7015

With hinged lid: No

With label space: Yes

Device width: 22,30 mm

Device height: 49,00 mm

Device depth: 25,40 mm

Packaging



8007352560215

Qtà 1 NR

Dim 2.2x5x0.25 [cm]

Weight 6.6 [g]



8007352560222

Qtà 2 NR

Dim 4.1x2.8x5.3 [cm]

Weight 13.2 [g]



8007352560239

Qtà 20 NR

Dim 14.4x9x6 [cm]

Weight 168.1 [g]

Legal

Vimar reserves the right to change at any time and without notice the characteristics of the products reported. Installation should be carried out by qualified staff in compliance with the current regulations regarding the installation of electrical equipment in the country where the products are installed. For the terms of use of the information on the product info sheet see [Conditions of Use](#).