

## "Reduced height" floor boxes



0 880 70 equipped with Mosaic sockets

Pack	Cat.No	50 mm "reduced height" floor boxes
1	0 880 70	<b>16 modules</b> For raised or screed floor between 50 and 70 mm Workstation connection for raised or concrete floors To be used with backbox Cat.No 0 880 73 (in concrete floors) or with insulation box Cat.No 0 880 71 (in raised floors) (see below) Supplied with cover for carpet Vertical wiring device positioning Ensures perfect cable separation Easy opening cover by handle To be equipped with Mosaic or Arteor wiring accessories With cover for carpet, grey RAL 7031 Can be equipped with stainless steel finishing plate Cat.No 0 880 72
1	0 880 72	<b>Stainless steel finishing plate</b> For 50 mm reduced height floor box Cat.No 0 880 70
		<b>Backboxes for shallow concrete floor and insulation boxes for raised floor</b> For integration of 50 mm "reduced height" floor boxes Cat.No 0 880 70 (see above) in raised or screed floor installations Power supply by flexible conduits Ø16, 20 and 25 mm or floor trunking 28 mm height
1	0 880 73	Backbox for shallow concrete floor
1	0 880 71	Insulation box for raised floors

## "Reduced height" floor boxes

### technical characteristics

#### "Reduced height" floor boxes

##### Installation principle

Installation in raised floor

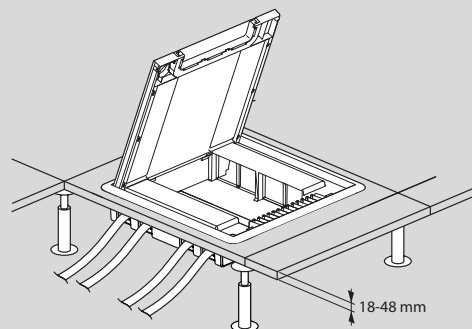
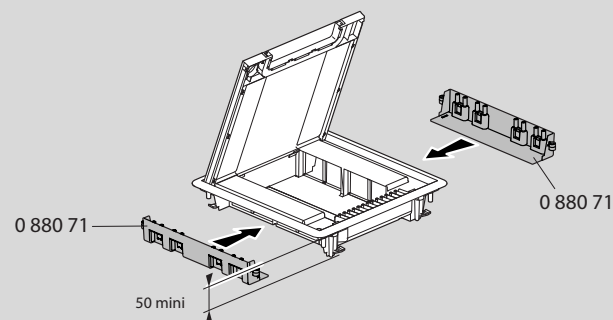
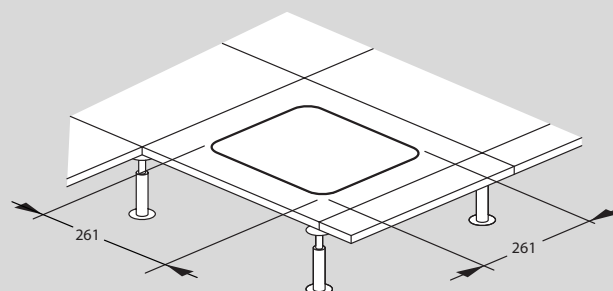

Installation in concrete floor

